

Job Name:	Date:
System Reference:	



Indoor Unit: MFZ-KJ15NA-U1



Wireless Remote Controller



Outdoor Unit: MUFZ-KJ15NAHZ-U1

ACCESSORIES:

Indoor Unit

- Condensate Pump (BlueDiamond X87-711/721; 115/230V)
- Condensate Pump (Sauermann SI30-115/230; 115/230V)
- Anti-Allergy Enzyme Filter (MAC-408FT-E)
- Drain Pan Level Sensor (DPLS2)

Outdoor Unit

- Outdoor Mounting Pad (ULTRILITE1)
- 3-1/4" Mounting Base [Pair] (DSD-400P)
- Air Outlet Guide (MAC-886SG)
- Wall Mounting Bracket (QSWB2000M-1)

Controls

- Wireless Controller (MHK1)
- Wired Remote Controller PAR-32MAA (Requires MAC-333IF-E)
- Wireless Interface for kumo cloud™ (PAC-WHS01WF-E)
- Thermostat Interface (PAC-US444CN-1)

SPECIFICATIONS:

Rated Conditions (Capacity / Input)

Cooling ¹	Btu/h / W	15,000 / 1,120
Heating at 47° F ²	Btu/h / W	18,000 / 1,410

Capacity Range	Minimum	Maximum
Cooling ¹	Btu/h	5,300
Heating at 47° F ²	Btu/h	5,700
Heating at 17° F ³	Btu/h	20,500
Heating at 5° F ⁴	Btu/h	18,000

¹ Cooling | Indoor: 80° F (27° C) DB / 67° F (19° C) WB; Outdoor: 95° F (35° C) DB / 75° F (24° C) WB*
² Heating at 47° F | Indoor: 70° F (21° C) DB / 60° F (16° C) WB; Outdoor: 47° F (8° C) DB / 43° F (6° C) WB*
³ Heating at 17° F | Indoor: 70° F (21° C) DB / 60° F (16° C) WB; Outdoor: 17° F (-8° C) DB / 15° F (-9° C) WB*
⁴ Heating at 5° F | Indoor: 70° F (21° C) DB / 60° F (16° C) WB; Outdoor: 5° F (-15° C) DB / 5° F (-15° C) WB*
 * Rating Conditions per AHRI Standard:

Operating Conditions (Indoor Intake Air Temp.) (Max./ Min.)

Cooling ⁵	90° F (32° C) DB / 67° F (19° C) DB
Heating	80° F (27° C) DB / 70° F (21° C) DB

Operating Conditions (Outdoor Intake Air Temp.) (Max./ Min.)

Cooling ⁵	115 F (46° C) DB / 14° F (-10° C) DB
Heating	75° F (24° C) DB / -4° F (-20° C) DB**

⁵ Applications should be restricted to comfort cooling only; equipment cooling applications are not recommended for low ambient temperature conditions.
 ** System cuts out at -18° F (-28° C) to avoid thermistor error and automatically restarts at -4° F (-20° C).

AHRI Efficiency Ratings

SEER / HSPF	21.8 / 11.6
COP at 47° F / 17° F	3.7 / 2.71

Energy Star®	Yes
---------------------	-----

ENERGY STAR products are third-party certified by an EPA-recognized Certification Body.

Specifications are subject to change without notice.

Electrical		
Electrical Power Requirements	208 / 230V, 1-Phase, 60 Hz	
MCA: Indoor Outdoor	A	1 16
Recommended Fuse/Breaker Size	A	20

Indoor Unit		
Blower Motor ECM Output	0.62 F.L.A. 30 W	
SHF Moisture Removal	0.66 3.9 pt./h	
Field Drainpipe Size O.D.	In.(mm)	5/8 (15)

Outdoor Unit		
Compressor	DC INVERTER-driven Twin Rotary	
Fan Motor (ECM)	F.L.A.	0.93

Airflow Rate (Quiet - Lo - Med - Hi - Super Hi)			
Indoor (Cooling)	DRY	CFM	198-254-311-392-431
	WET		168-216-264-333-366
Indoor (Heating)	DRY		212-268-328-399-470
Outdoor			1,653 / 1,730

Sound Pressure Level (Quiet - Lo - Med - Hi - Super Hi)		
Indoor: Cooling Heating	dB(A)	28-33-38-43-47 29-35-40-45-49
Outdoor: Cooling Heating		51 55

Unit Dimensions		
Indoor Outdoor (H x W x D)	In.	23-5/8 x 29-17/32 x 8-15/32 34-5/8 x 33-1/16 x 13
	mm	600 x 750 x 215 880 x 840 x 330

Package Dimensions		
Indoor Outdoor (H x W x D)	In.	27-3/4 x 32-3/4 x 12 39 x 38-3/4 x 16-3/4
	mm	693 x 816 x 275 990 x 980 x 420

Unit/Package Weight		
Unit: Indoor Outdoor	Lbs.(kg)	33 (15) 124 (56)
Package: Indoor Outdoor	Lbs.(kg)	41 (18.5) 144 (65)

External Finish	
Indoor Outdoor	Munsell 1.0Y 9.2 / 0.2 Munsell No. 3Y 7.8 / 1.1

Refrigerant	R410A; 3 lb. 5 oz.
--------------------	--------------------

Refrigerant Piping (Flared)		
Liquid (High Pressure)	In.(mm)	1/4 (6.35)
Gas (Low Pressure)		1/2 (12.7)
Max. Total Refrigerant Pipe Length (Height Diff.)	Ft. (m)	50 (15)
Max. Total Refrigerant Pipe Length (Length.)		100 (30)

DIMENSIONS: MFZ-KJ15NA-U1 & MUFZ-KJ15NAHZ-U1

MFZ-KJ15NA-U1

Unit: in.

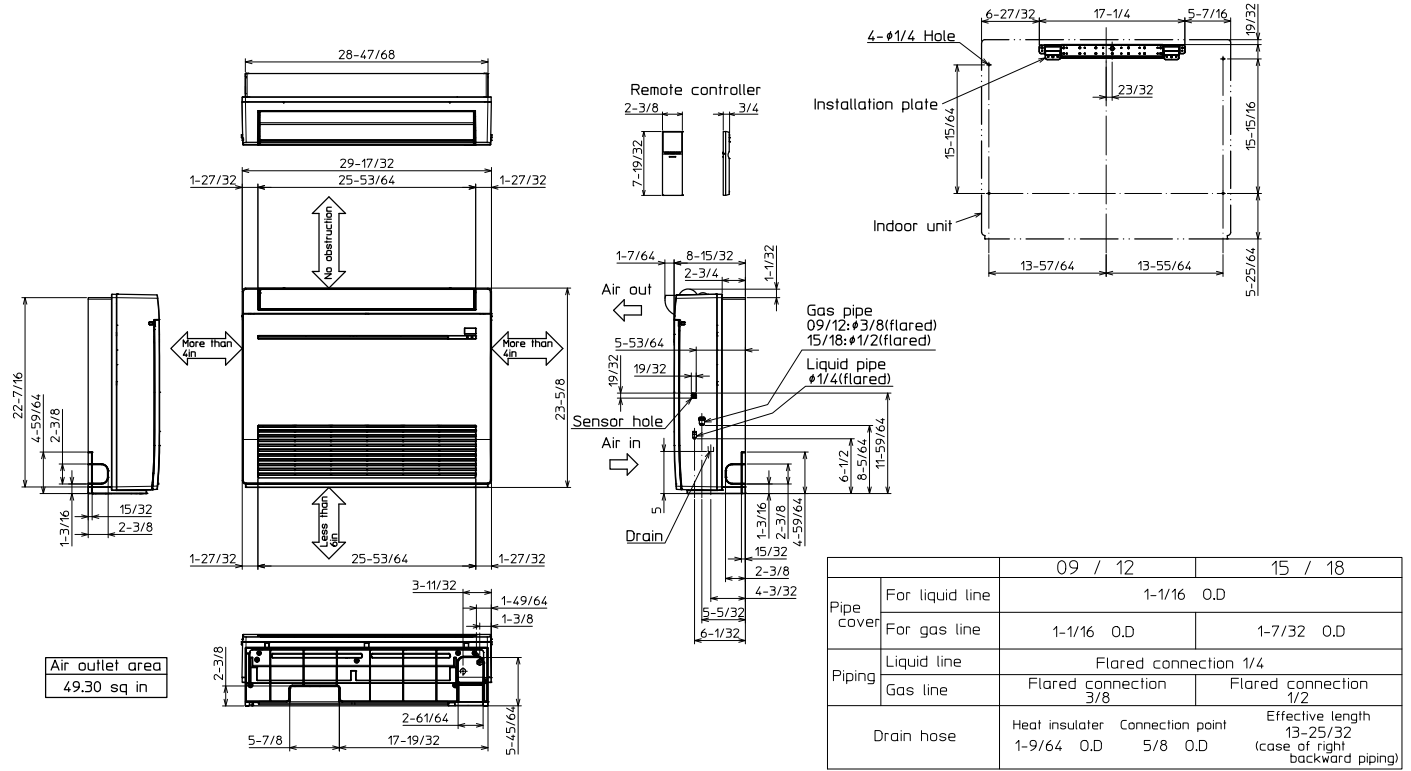

MUFZ-KJ15NAHZ-U1

Unit: in. (mm)

REQUIRED SPACE

*1 20 in. (500 mm) or more when front and sides of the unit are clear

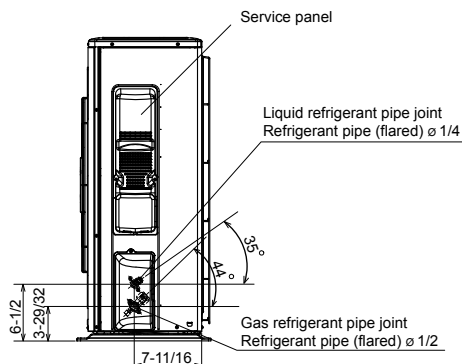
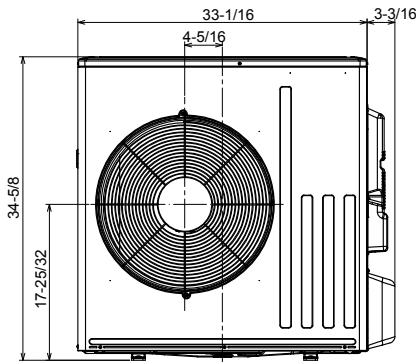
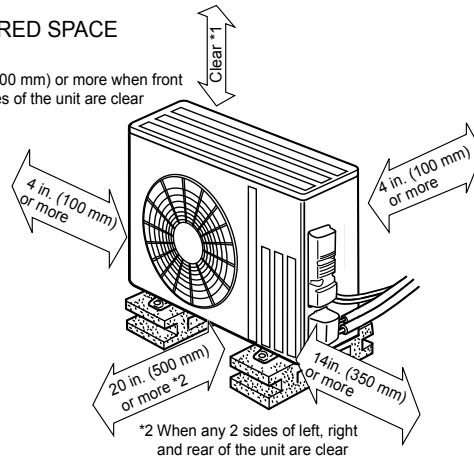
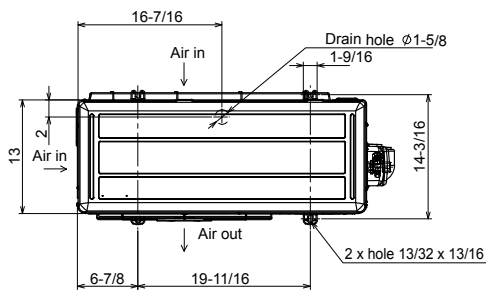

COOLING & HEATING

1340 Satellite Boulevard, Suwanee, GA 30024
 Toll Free: 800-433-4822 www.mehvac.com