

PART NUMBER	A	B
497-3804-00	15.717	15.288
497-3804-01	15.717	15.288
497-3804-02	15.467	15.038

SPECIFICATIONS	
ES NO.	DESCRIPTION
ES22-122	PACKAGING
ES81-159	CLEANLINESS
ES81-250	IDENTIFICATION
ES92-167	REGULATORY COMPLIANCE

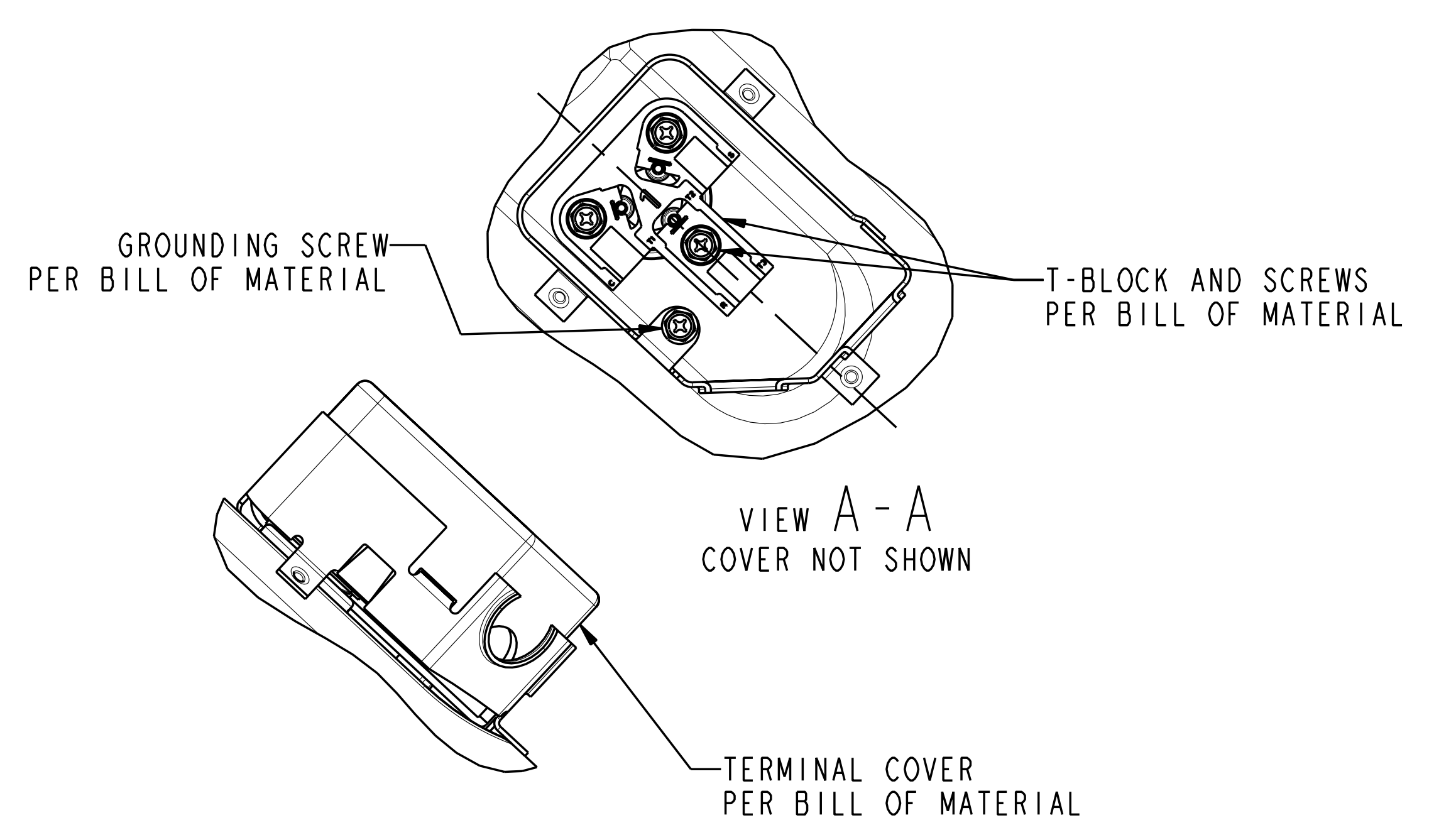
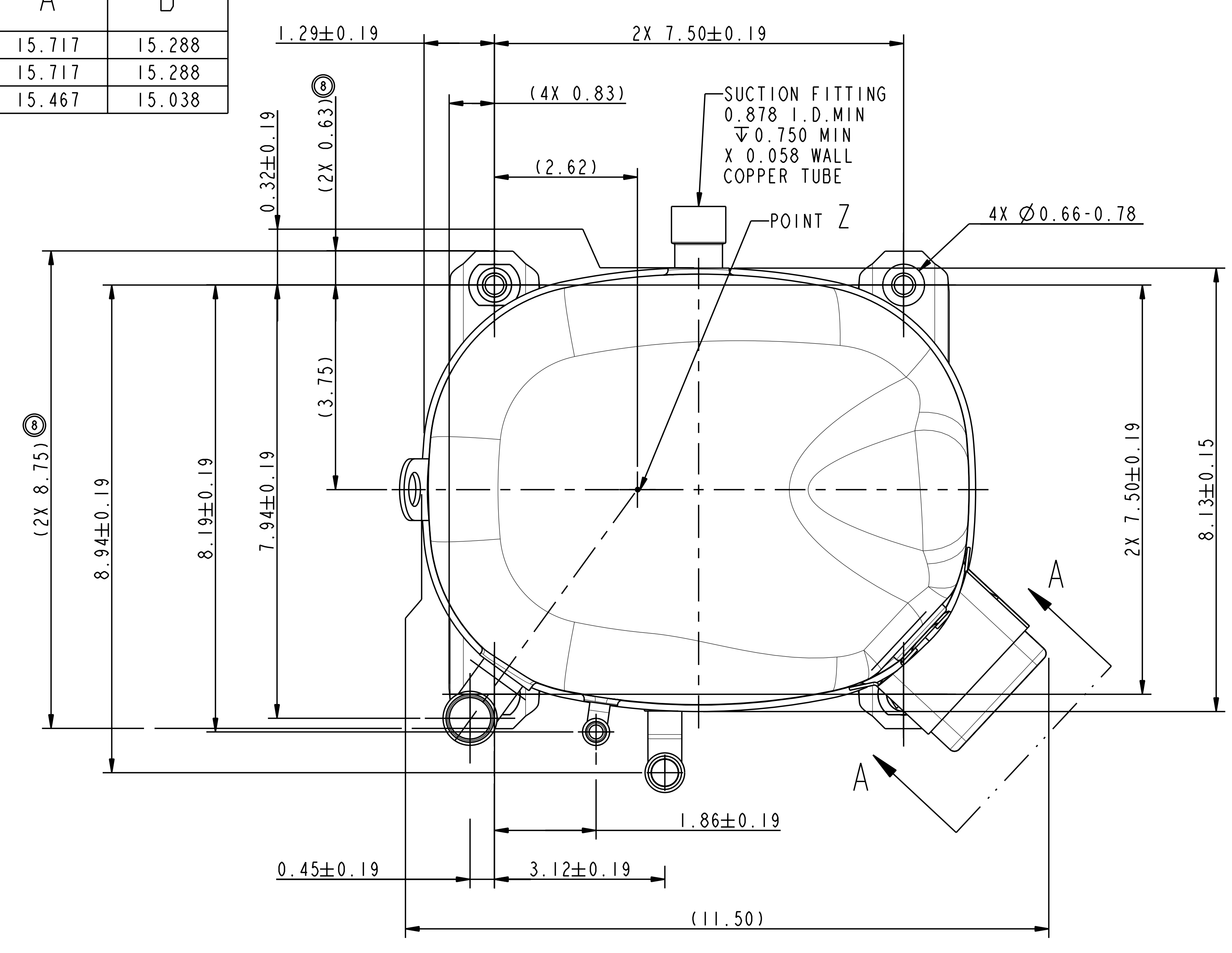

DUE TO ACCUMULATED ASSEMBLY TOLERANCES THE LISTED COMPONENTS MAY VARY FROM THE MOUNTING HOLES AS TABULATED.

DISCHARGE TUBE	±0.125
SUCTION TUBE	±0.187
PROCESS TUBE	±0.187

- NOTES:
- TOLERANCES TO BE ±0.12 UNLESS OTHERWISE SPECIFIED.
 - TUBE ENDS MUST BE PLUGGED.
 - SERVICE KIT SHIPS WITH MODEL. BOXED KIT INCLUDES: MOUNTING PARTS, CRANKCASE HEATER, T-BLOCK & SCREWS

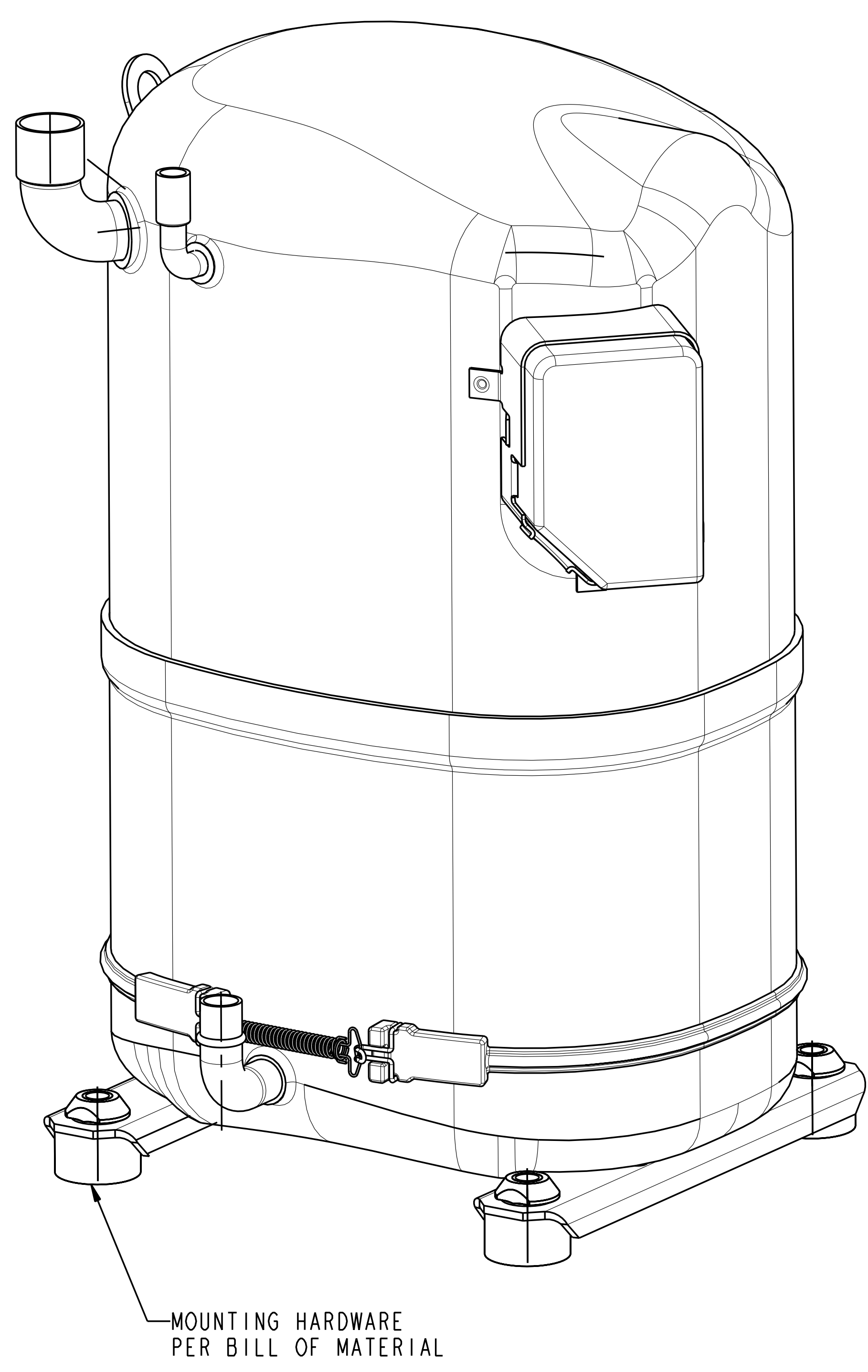
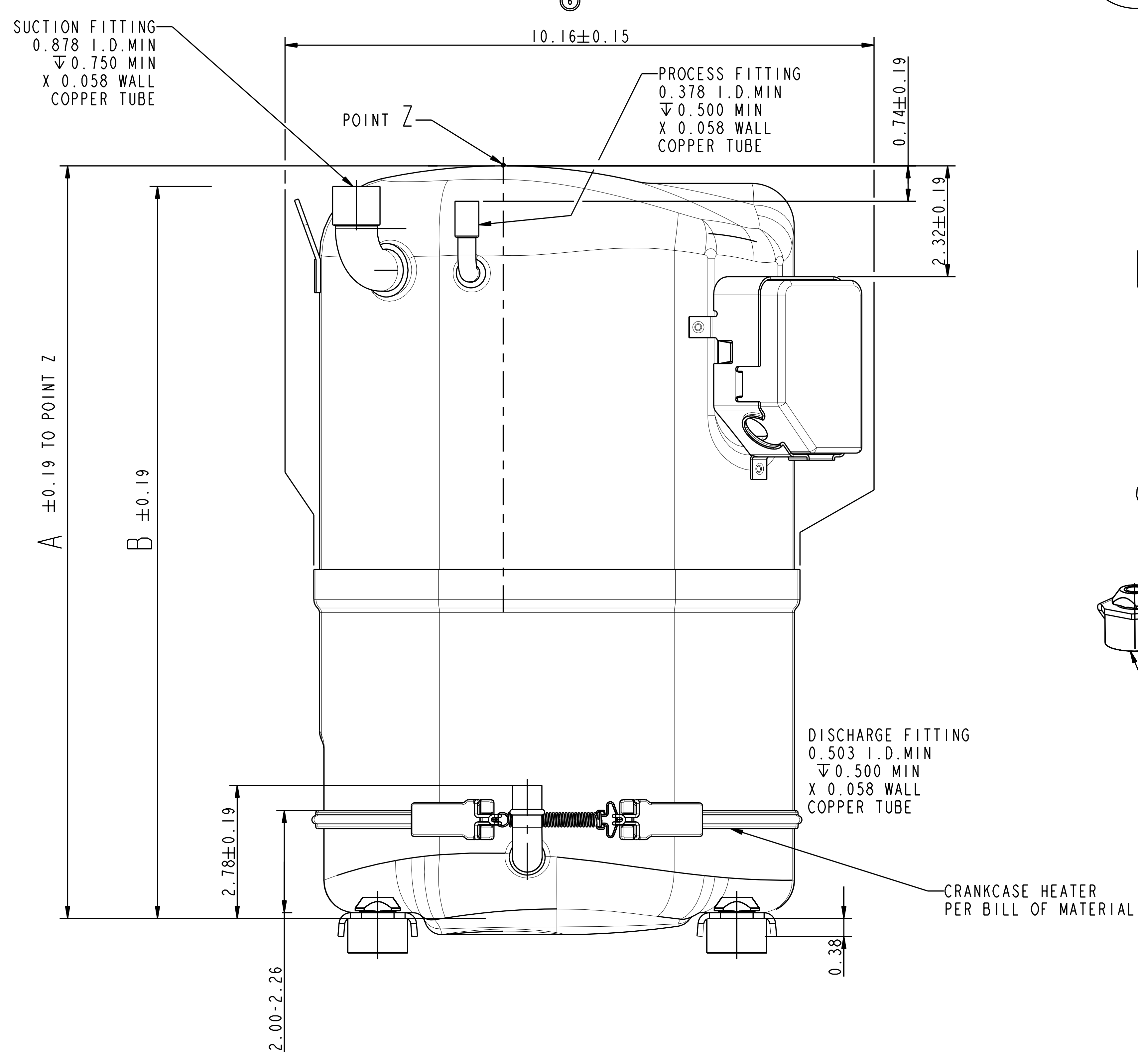

MODEL/PART CROSS REF			
MODEL NUMBER	PART NUMBER FOR SE -970	PART NUMBER FOR SE -556	
CRNO-0500-PFV	497-3804-00	497-3804-01	
CRNO-0500-TF5			
CRNO-0500-TFD			
CRNO-0500-TFE			
CRNO-050E-PFV			
CRNO-050E-TF5			
CRNO-050E-TFD			
CRNO-050E-TFE			
CRN5-0500-PFV			--
CNR5-0500-TFD			--
CRN5-0500-TFE	--		
CRN5-0500-TF5	--		
CRPO-045E-PFV	--	--	
CRPO-045E-TFD	--	--	
CRPO-045E-TFE	--	--	
CRPO-045E-TF5	--	--	
CR60K5-PFV	--	497-3804-02	
CR60K5-TF5	--		
CR60K5-TFD	--		
CRP5-0450-PFV	--	497-3804-01	
CRP5-0450-TF5	--		
CRP5-0450-TFD	--		
CRP5-0450-TFE	--	--	

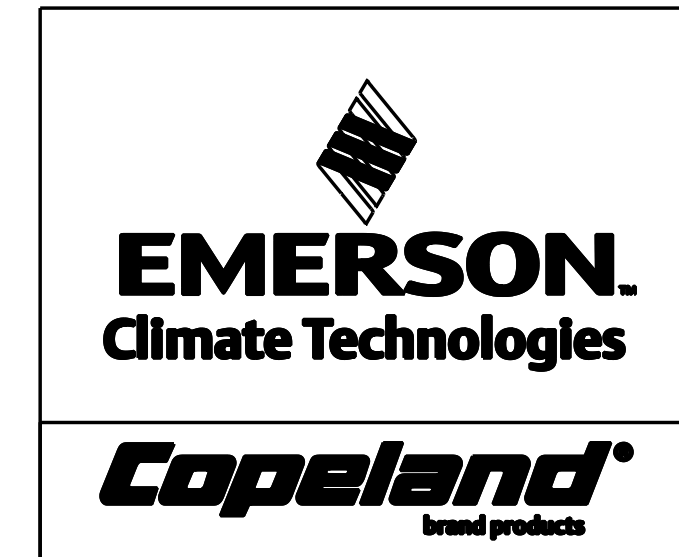

INTERPRET PER ASME Y14.5M-1994 AND EMERSON CLIMATE TECHNOLOGIES, INC. DESIGN STANDARDS DS2002. DO NOT SCALE DRAWING. THIRD ANGLE PROJECTION.

UNLESS OTHERWISE SPECIFIED DIMENSIONS ARE INCH OR (MILLIMETER)

TOLERANCES:
 2-PLACE ± N/A
 3-PLACE ± N/A
 ANGULAR ± N/A

ECN	REV. NO.	DESCRIPTION	DATE	BY	CHKD	APPR
ECN006685	8	UPDATED PRINT	11-12-13	ACL	BAH	EJT
ECN007268	7	ADDED MODELS IN MODEL NUMBER TABLE	08-13-13	DKM	BAH	EJT
ECN004797	6	REDRAWN WITH CHANGES	12-22-11	DB	BAH	EJT
ECN002583	0	RELEASED	08-16-10	KRB	BAH	BAH

REVISIONS		SUPERSEDES DWG. NO. / REV. NO.	
3	THIS DRAWING AND INFORMATION CONTAINED HEREIN ARE THE EXCLUSIVE PROPERTY OF EMERSON CLIMATE TECHNOLOGIES, INC. AND SHALL BE RETURNED UPON DEMAND AND SHALL NOT BE REPRODUCED IN WHOLE OR IN PART, DISCLOSED TO ANYONE ELSE OR USED, WITHOUT THE WRITTEN CONSENT OF EMERSON CLIMATE TECHNOLOGIES, INC.	497-3804-00	05
DATE	SCALE	DATE FORMAT	MM-DD-YY
12-22-11	1:2		
TITLE		DRAWING NUMBER SHEET 1 OF 1	
REF DWG - WELD COMP ASSM		497-3804-00	