

UNIT MODEL NUMBER	COMPRESSOR_MODEL_NO	PUMPDOWN_CAPACITY
M4FL-H025-1AA-072	AFE08C4E-1AA	R-404A 4.6 LBS.

- NOTES:
- PUMPDOWN CAPACITY AT 90%:  
(SEE TABLE)
  - ALL OPENINGS MUST BE CAPPED OR PLUGGED.

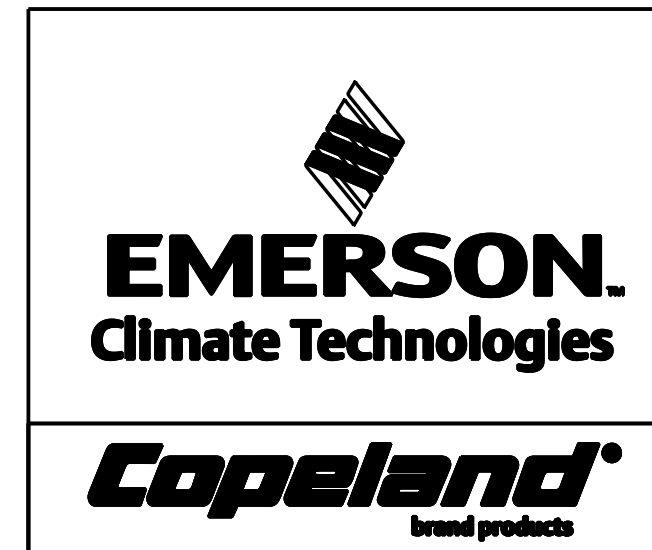
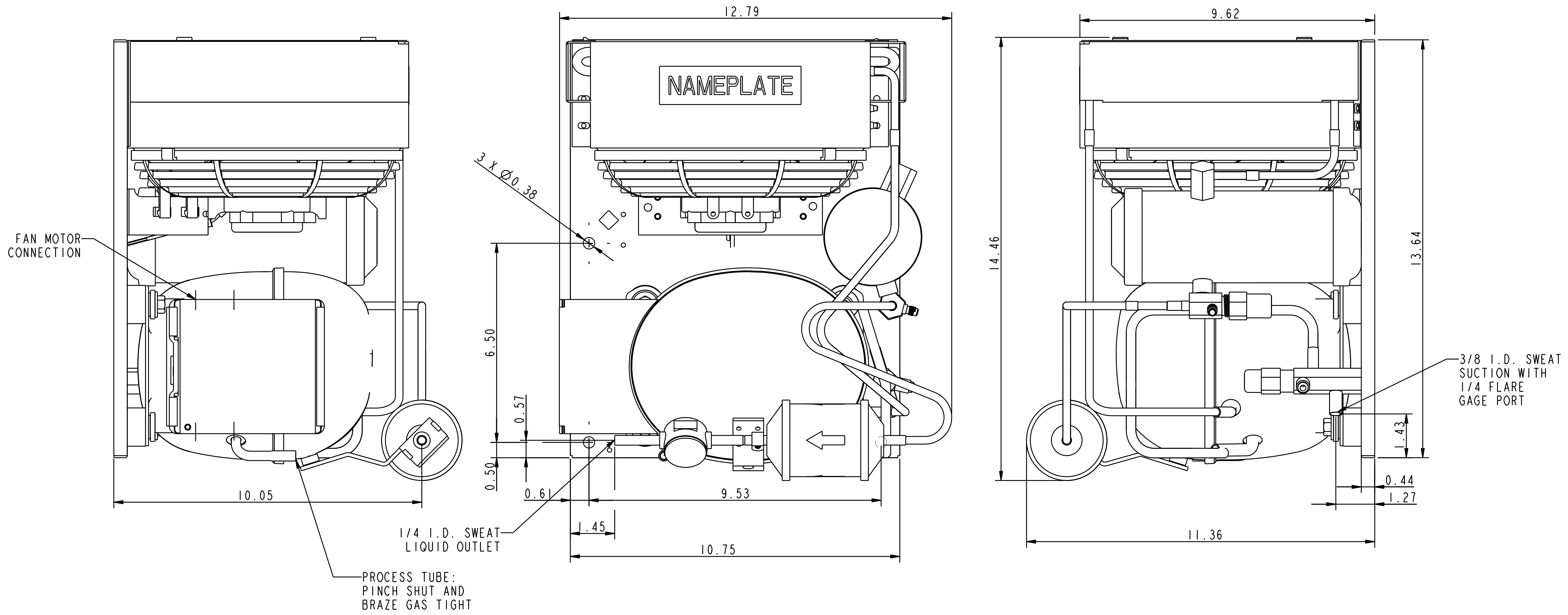

INTERPRET PER ASME Y14.5M-1994 AND EMERSON CLIMATE TECHNOLOGIES, INC. DESIGN STANDARDS DS2002 DO NOT SCALE DRAWING

THIRD ANGLE PROJECTION

CRITICAL PRODUCT CHARACTERISTIC

UNLESS OTHERWISE SPECIFIED DIMENSIONS ARE INCH OR (MILLIMETER)

TOLERANCES:  
2-PLACE ±  
3-PLACE ±  
ANGULAR ±

ECN006842	1	REVISE BRACKET	05-23-13	BAJ		
ECN005862	0	RELEASED	06-25-12	PSB	TR	
ENG NOTICE NO.	REV. NO.	REVISIONS	DATE	BY	CHKD	APPR
6		<p>CONFIDENTIALITY NOTICE</p> <p>THIS DRAWING AND INFORMATION CONTAINED HEREIN ARE THE EXCLUSIVE PROPERTY OF EMERSON CLIMATE TECHNOLOGIES, INC. AND SHALL BE RETURNED UPON DEMAND AND SHALL NOT BE REPRODUCED IN WHOLE OR IN PART, DISCLOSED TO ANYONE ELSE OR USED, WITHOUT THE WRITTEN CONSENT OF EMERSON CLIMATE TECHNOLOGIES, INC.</p>				
MATERIAL SPECIFICATION		DRAWN BY	SUPERSEDES DWG. NO. / REV. NO.			
		PSB	/			
		DATE	SCALE	DATE FORMAT:		
		06-25-12	5:8	MM-DD-YY		
TITLE		DRAWING NUMBER	SHEET 1 OF 1		DWG	
REF. DWG. - WELD UNIT ASSM		496-7114-01			4	
		SIZE				

UNCONTROLLED - DO NOT MODIFY

COPYRIGHT EMERSON CLIMATE TECHNOLOGIES, INC. - CONFIDENTIAL