

UNIT MODEL NUMBER	COMPRESSOR MODEL NO
XFAM-022Z-CFV-081	ZS15KAE-PFV

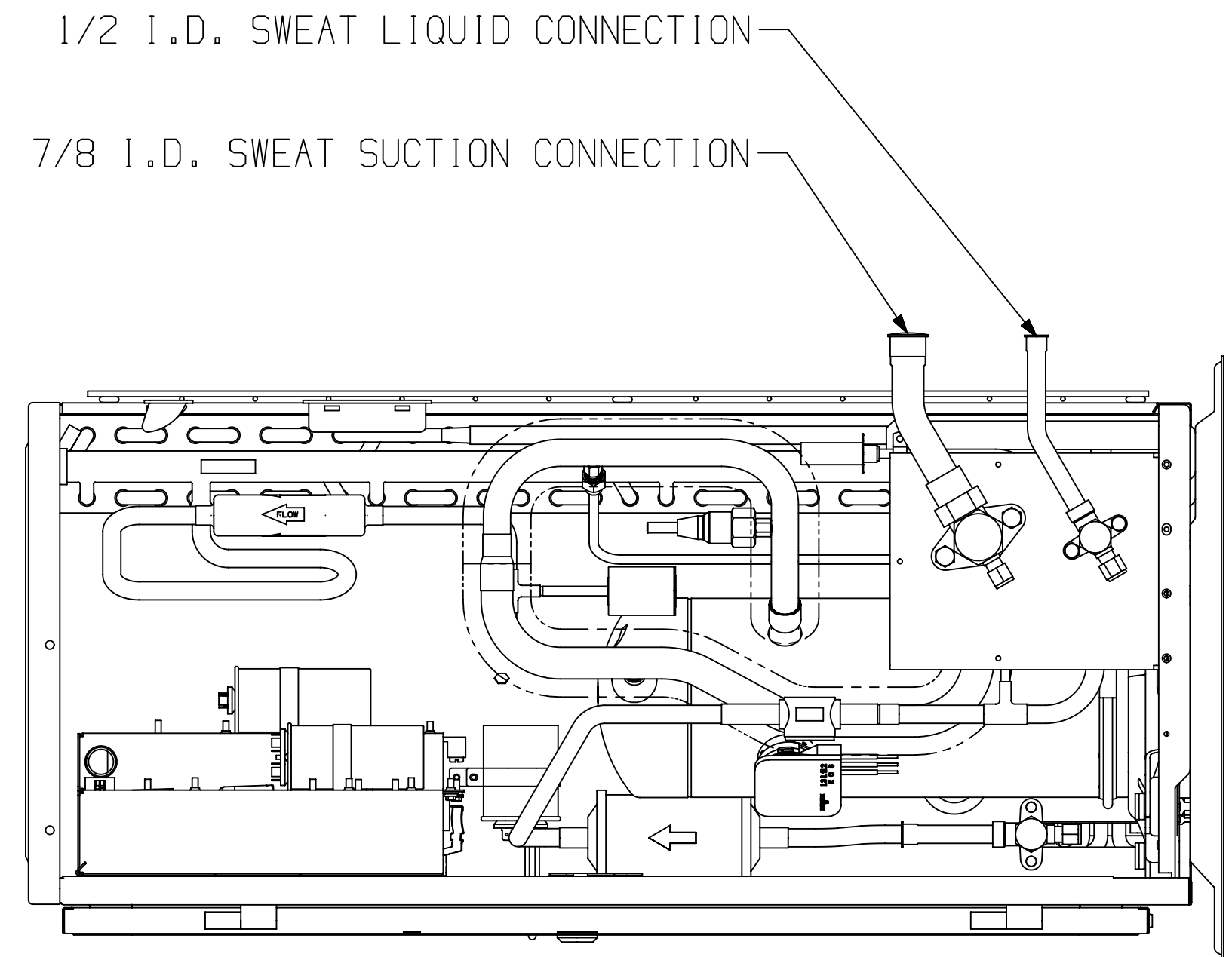

- NOTES:
- RECEIVER PUMPDOWN CAPACITY AT 90%
R-12 11.6 LBS
R-22 10.5 LBS
R-134a 10.6 LBS
R-404A 9.1 LBS
R-407A 10.0 LBS
R-407C 9.9 LBS
R-502 10.6 LBS
R-507 9.1 LBS
 - ALL OPENINGS MUST BE CAPPED OR PLUGGED

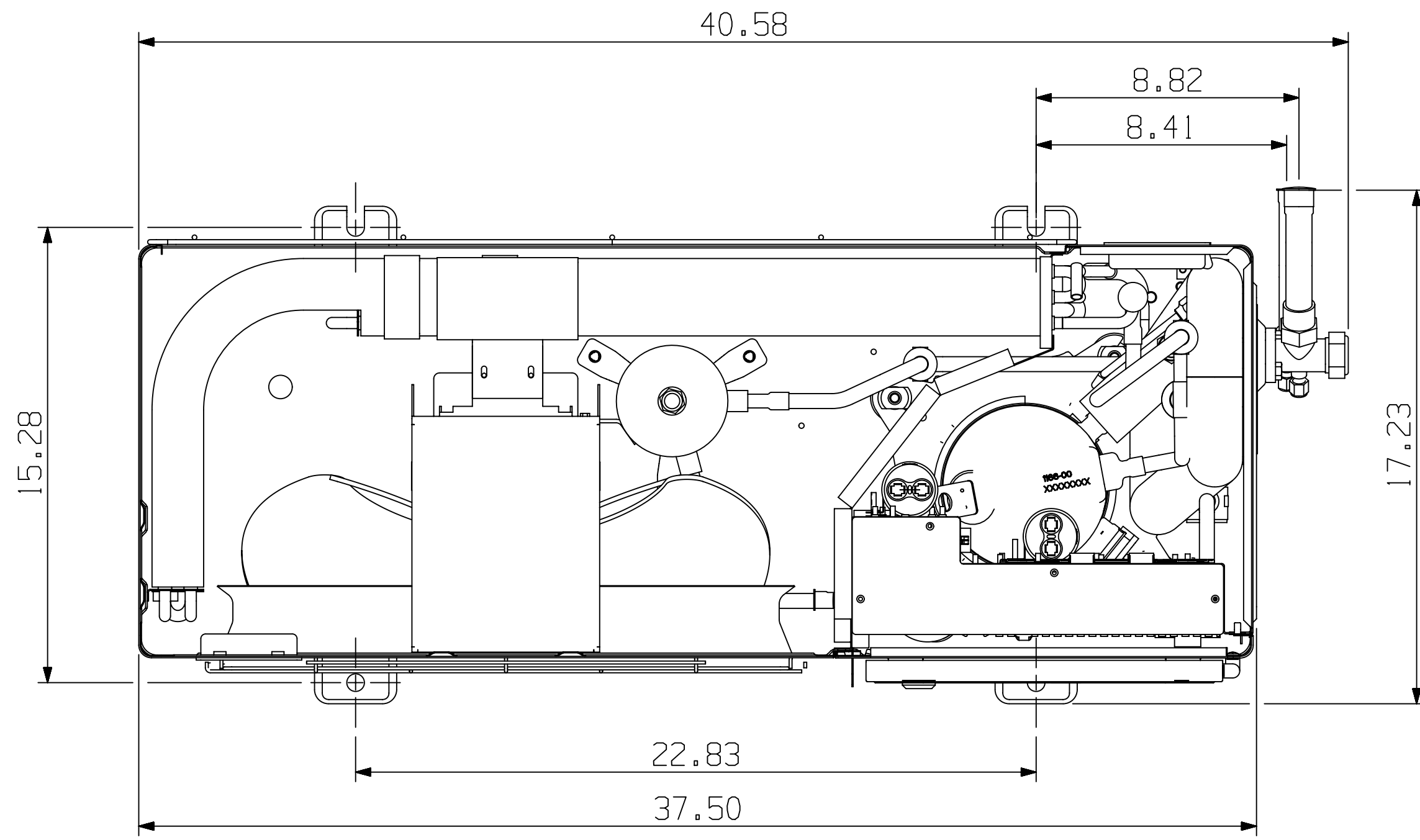
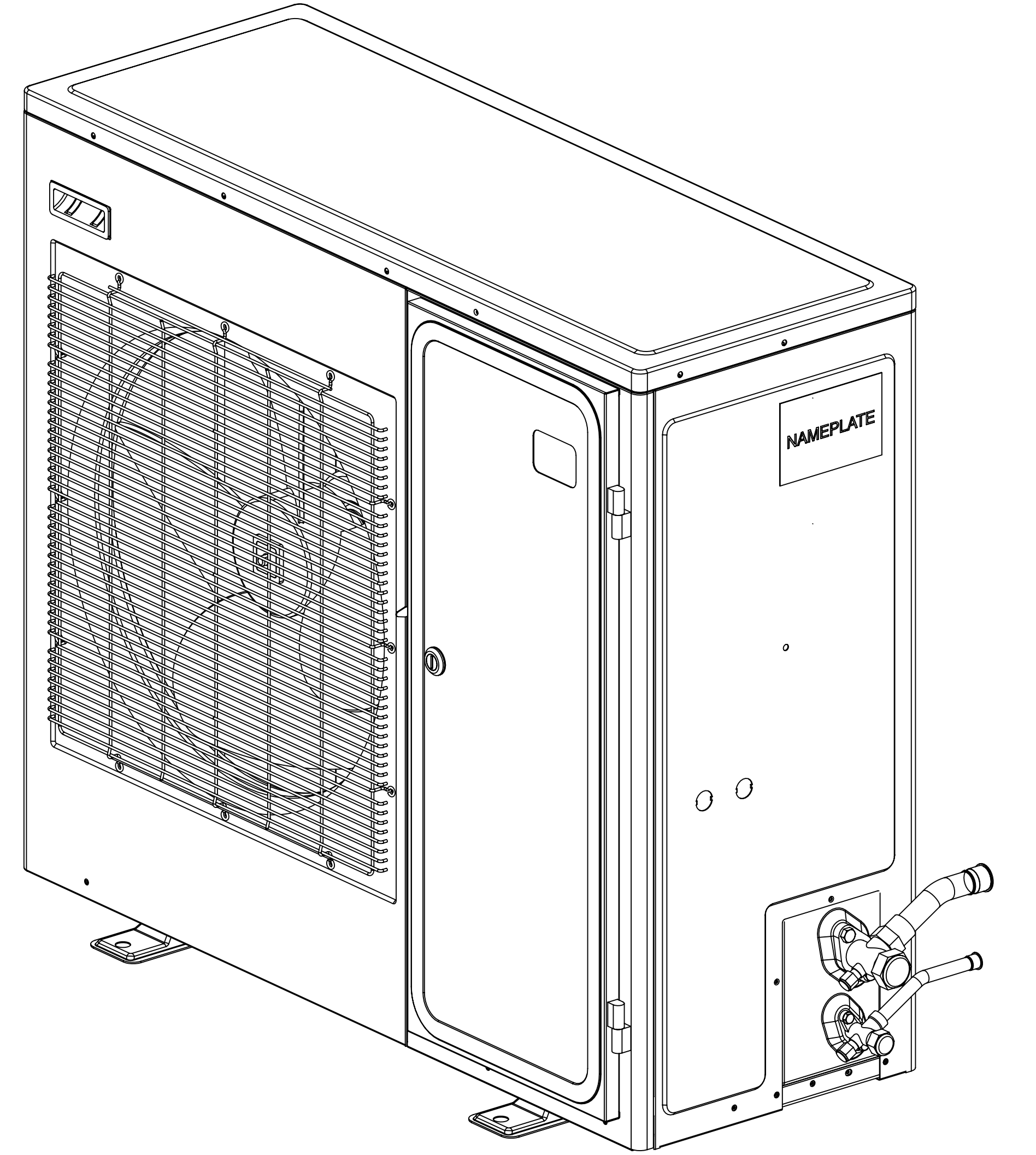
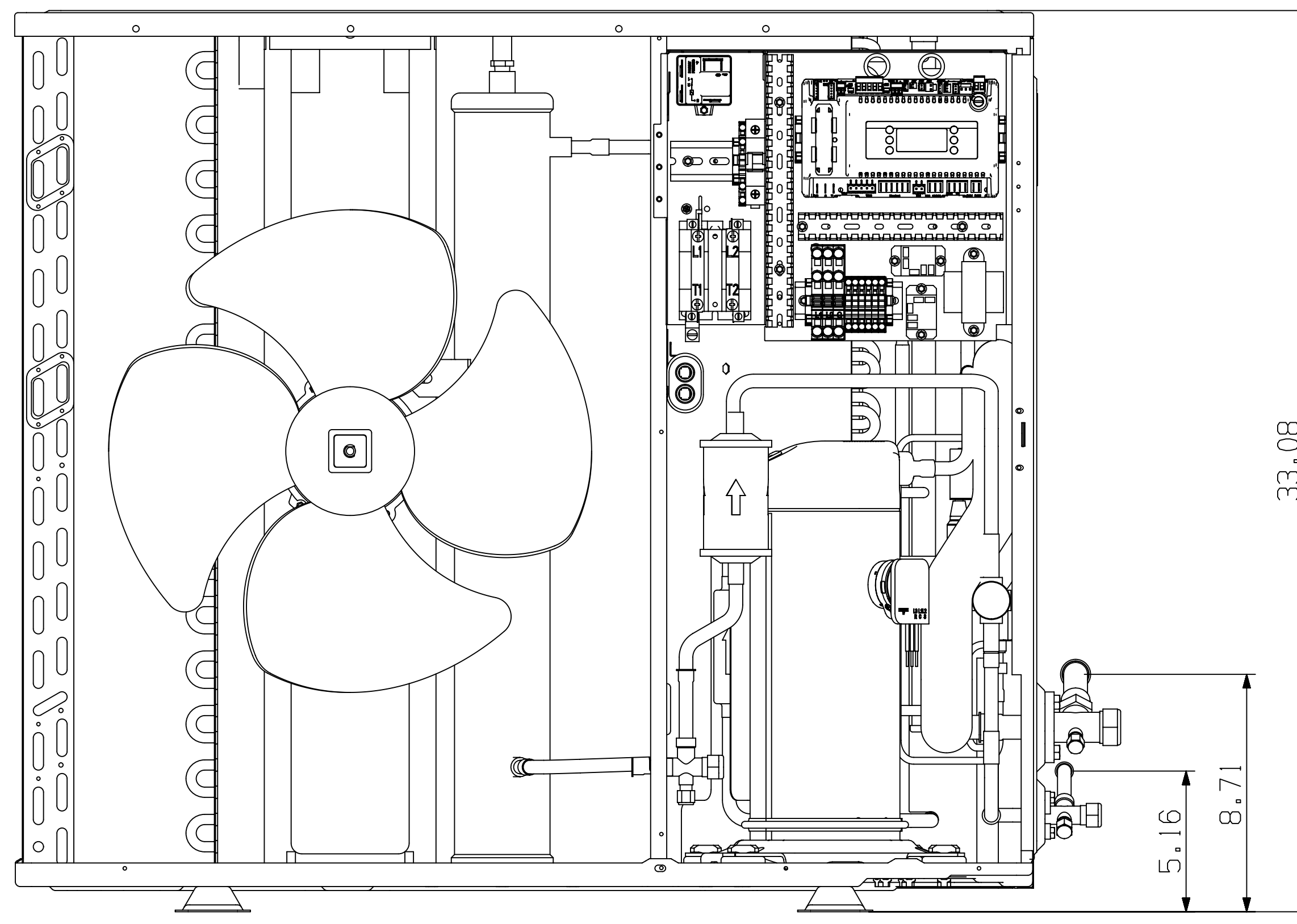

INTERPRET PER ASME Y14.5M-1994 AND EMERSON CLIMATE TECHNOLOGIES, INC. DESIGN STANDARDS DS2002
DO NOT SCALE DRAWING
THIRD ANGLE PROJECTION
CRITICAL PRODUCT CHARACTERISTICS
UNLESS OTHERWISE SPECIFIED DIMENSIONS ARE INCH OR (MILLIMETER)
TOLERANCES:
2-PLACE ±
3-PLACE ±
ANGULAR ±

ECN102523	0	RELEASED	10-14-15	ADS	TR	
ENG NOTICE NO.	REV.NO.	REVISIONS	DATE	BY	CHKD	APPR
CONFIDENTIALITY NOTICE						
THIS DRAWING AND INFORMATION CONTAINED HEREIN ARE THE EXCLUSIVE PROPERTY OF EMERSON CLIMATE TECHNOLOGIES, INC. AND SHALL BE RETURNED UPON DEMAND AND SHALL NOT BE REPRODUCED IN WHOLE OR IN PART DISCLOSED TO ANYONE ELSE OR USED, WITHOUT THE WRITTEN CONSENT OF EMERSON CLIMATE TECHNOLOGIES, INC.						
MATERIAL SPECIFICATION		DRAWN BY	SUPERSEDES DWG. NO. / REV. NO.			
		ADS	/			
		DATE	SCALE	DATE FORMAT:		
		10-14-15	1:4	MM-DD-YY		
TITLE		DRAWING NUMBER	SHEET 1 OF 1		DWG	
REF DWG-WELD UNIT ASSM		496-5743-01			4	
					SIZE	