

UNIT MODEL NUMBER	COMPRESSOR MODEL NO
XFAM-030Z-TFC-081	ZS21KAE-TF5

NOTES:

- UNIT PUMPDOWN CAPACITY AT 90%
R-12 11.6 LBS
R-22 10.5 LBS
R-134a 10.6 LBS
R-404A 9.1 LBS
R-407A 10.0 LBS
R-407C 9.9 LBS
R-502 10.6 LBS
R-507 9.1 LBS
- ALL OPENINGS MUST BE CAPPED OR PLUGGED

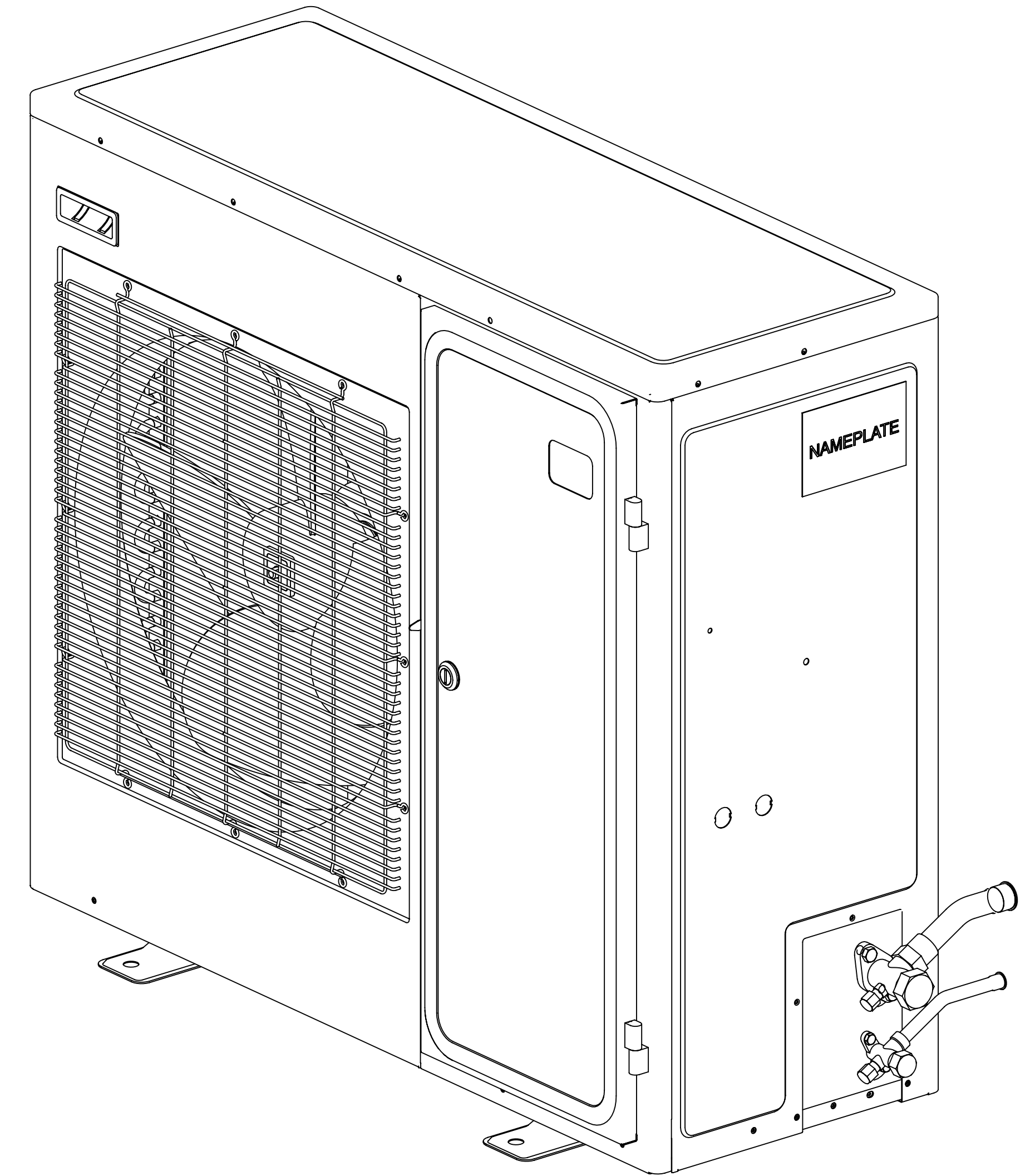
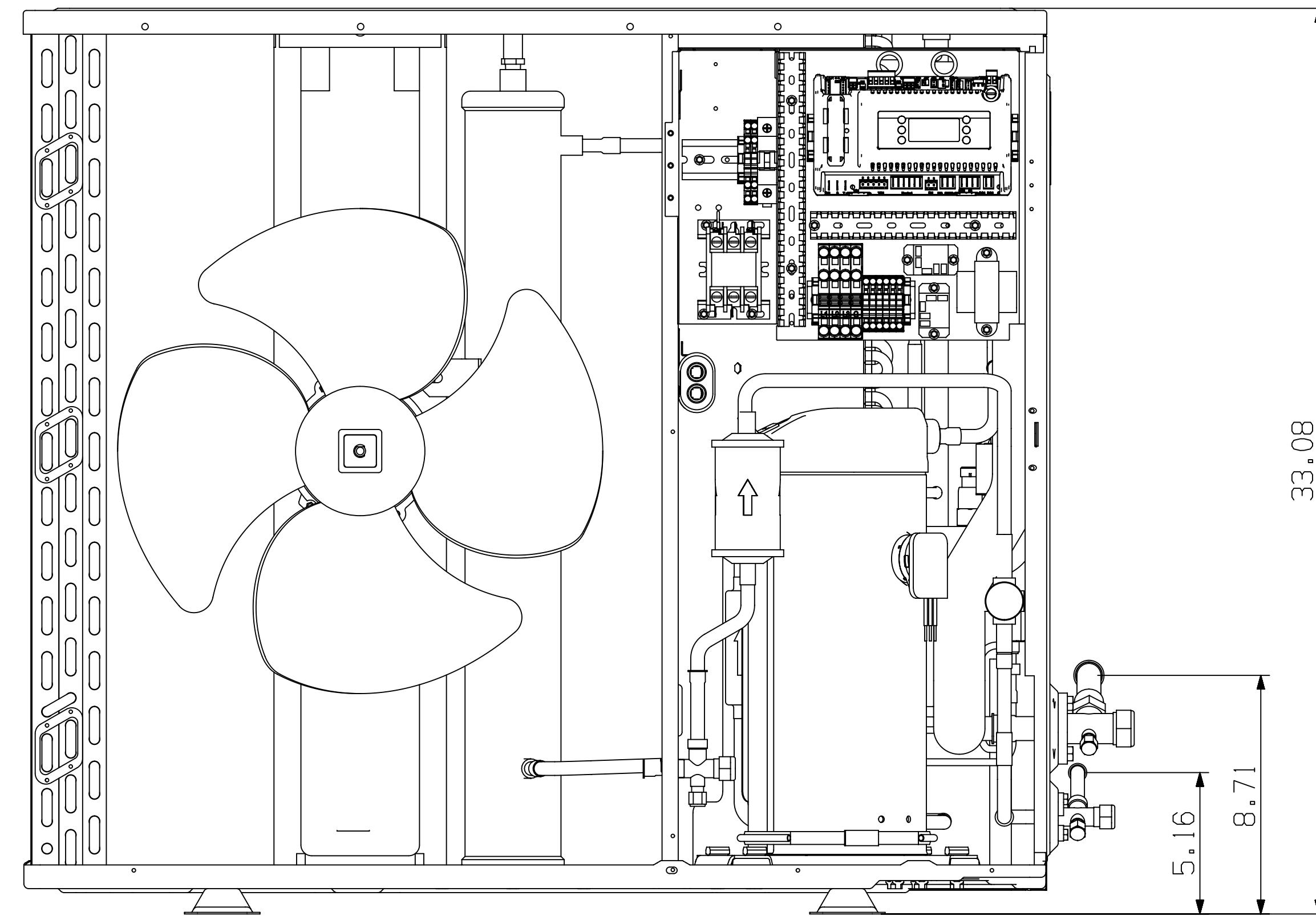
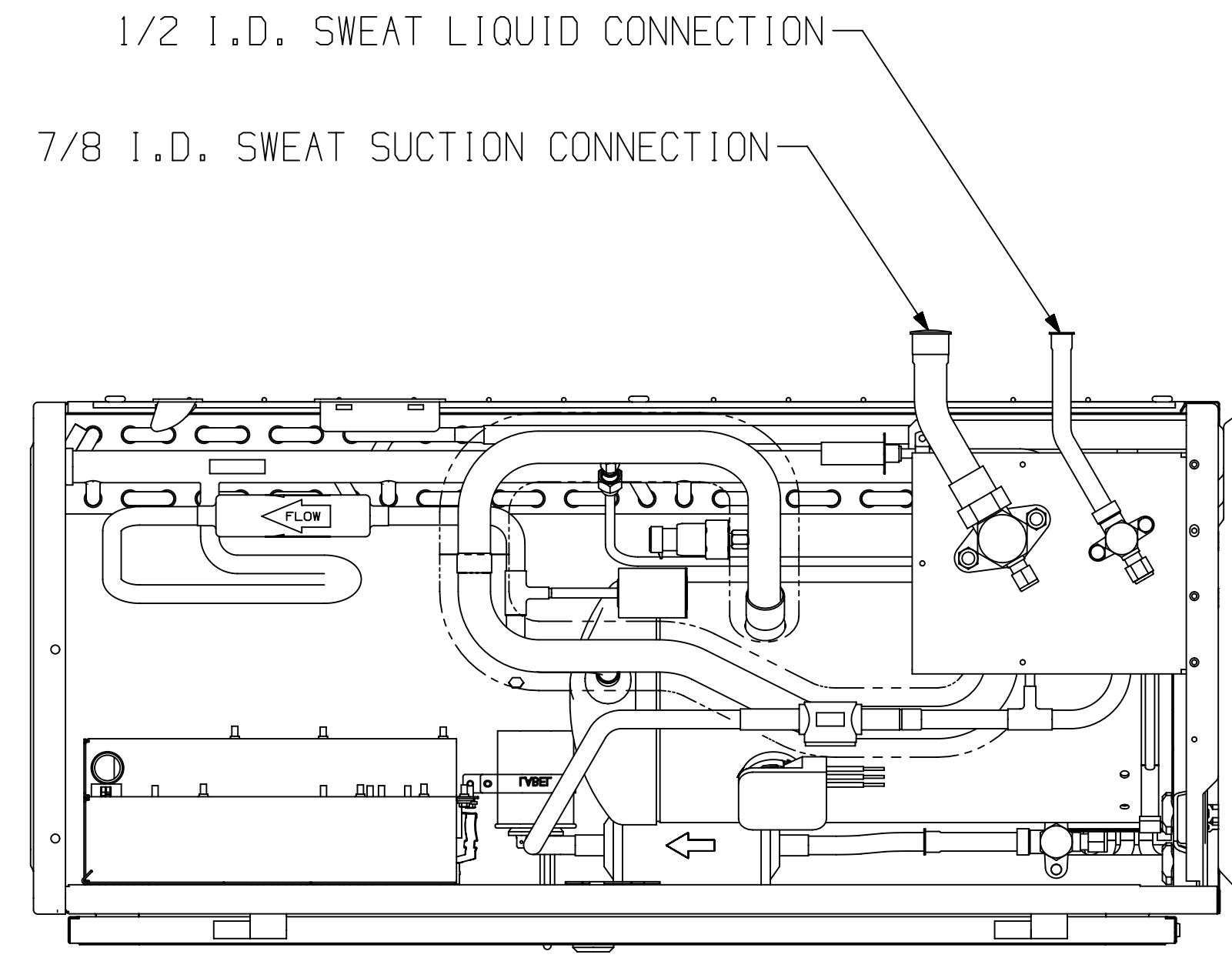
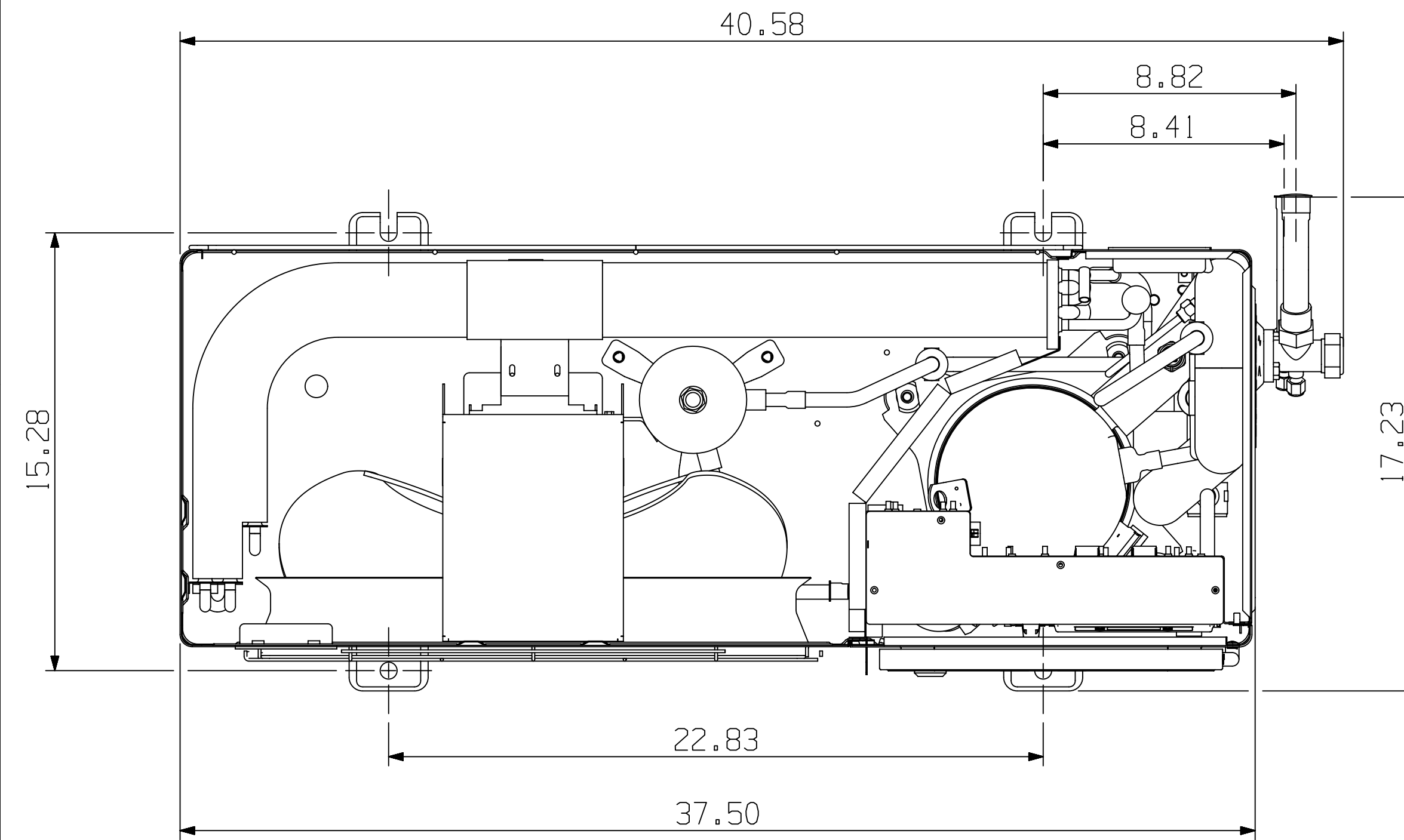

 	INTERPRET PER ASME Y14.5M-1994 AND EMERSON CLIMATE TECHNOLOGIES, INC. DESIGN STANDARDS DS2002 DO NOT SCALE DRAWING THIRD ANGLE PROJECTION		UNLESS OTHERWISE SPECIFIED DIMENSIONS ARE INCH OR (MILLIMETER) TOLERANCES: 2-PLACE ± 3-PLACE ± ANGULAR ±	
	CRITICAL PRODUCT CHARACTERISTICS	DRAWN BY PHK DATE 10-21-15	SUPERSEDES DWG. NO. / REV. NO. /	SCALE 1:4 DATE FORMAT: MM-DD-YY
TITLE REF. DWG. - WELD UNIT ASSM.		DRAWING NUMBER 496-5733-08	SHEET 1 OF 1 4 SIZE	

ECN102484	0	RELEASED	10-21-15	PHK	TR
ENG NOTICE NO.	REV.NO.	REVISIONS	DATE	BY	CHKD

CONFIDENTIALITY NOTICE					
THIS DRAWING AND INFORMATION CONTAINED HEREIN ARE THE EXCLUSIVE PROPERTY OF EMERSON CLIMATE TECHNOLOGIES, INC. AND SHALL BE RETURNED UPON DEMAND AND SHALL NOT BE REPRODUCED IN WHOLE OR IN PART DISCLOSED TO ANYONE ELSE OR USED, WITHOUT THE WRITTEN CONSENT OF EMERSON CLIMATE TECHNOLOGIES, INC.					
MATERIAL SPECIFICATION		DRAWN BY		SUPERSEDES DWG. NO. / REV. NO.	
		PHK		/	
		DATE		SCALE	
		10-21-15		1:4	
TITLE		DRAWING NUMBER		SHEET 1 OF 1	
REF. DWG. - WELD UNIT ASSM.		496-5733-08		4	