

SAFE-T-SWITCH® SS610E WIRING DIAGRAM



Wiring diagram for MITSUBISHI ductless minisplit system fitted with SS610E Electronic Overflow Condensate Switch

1. (Internal Installation) Place switch inside indoor unit enclosure or line set cover.
(External Installation) Mount switch to a surface using double-sided tape or fasten using a screw.
2. Route lead wire into wiring space. Route sensor into evaporator space. Do not cut sensor wire. If necessary, remove bracket from sensor before routing.
3. Sensor mounting to pan:
 - a. Attach sensor to pan bracket.
 - b. Clip the pan bracket to where water level will be the highest in the indoor coil condensate pan, press firmly in place.
 - c. Position the wires up and probe pins down.
 - d. Adjust sensor height by pushing the sensor into the pan bracket. The pan bracket has a one-way ratchet mechanism. If the sensor is set too low in the pan, push the sensor from the lead side until it disengages from the pan bracket, then reset. Adjust the sensor so that the probe pins are below the rim of the condensate pan. The switch will trip when water level reaches probe pins.
4. Sensor mounting to coil:
 - a. Attach sensor to coil bracket. The coil bracket has 2 optional clips, one for regular 7mm coil and the other for 5mm coil. Choose clip size according to the actual coil tube diameter.
 - b. Clip the coil bracket onto indoor coil. Insert the bracket clip between the fins or at the coil U-bend.
 - c. Position the wires up and probe pins down.
 - d. Adjust sensor height by ratcheting sensor to where water level will be the highest in the indoor coil condensate pan. Adjust the sensor so that the probe pins are below the rim of the condensate pan. The switch will trip when water level reaches probe pins.
5. Wiring Option 1: Interfering power line
 - e. CONFIRM MAIN POWER SUPPLY IS SHUT OFF. Read air conditioner installation manual for the wiring terminal layout. Connect "power" wires to indoor unit power supply terminal.
 - f. Cut power wire of the indoor unit. Wire "COM-NC" and "NC" wires as shown in figure below. Insulate the "COM-NO" and "NO" wires using insulating tape." with "Follow option 1 wiring diagram below"
 - g. **⚠ WARNING** Electric shock hazard. Failure to insulate unused switch wires may cause personal injury and/or property damage.)
 - h. Use a wire nut when connecting wire to wire.
6. Wiring Option 2: Interfering built-in shut-off circuit
 - a. CONFIRM MAIN POWER SUPPLY IS SHUT OFF.
 - b. Read air conditioner installation manual for the location and wiring of external shut-off terminal (or overflow switch terminal).
 - c. Use a wire nut when connecting wire to wire.

Option 01 Wiring Diagram

110-230V AC

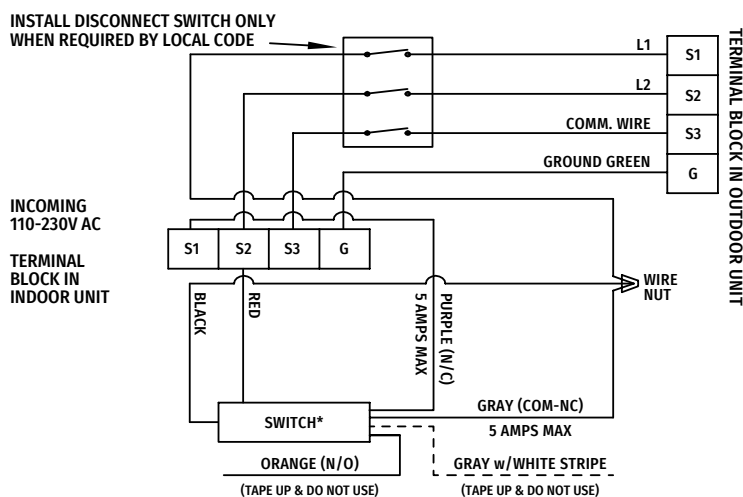

***NOTE:** Switch relays are shown with power applied to device.