

**MSZ-GS12NA & MUZ-GS12NAHZ**  
**12,000 BTU/H WALL-MOUNTED INDOOR UNIT**  
**12,000 BTU/H HYPER HEAT PUMP OUTDOOR UNIT**



Job Name:

System Reference:

Date:

Indoor Unit.....MSZ-GS12NA

Outdoor Unit.....MUZ-GS12NAHZ



**INDOOR UNIT FEATURES**

- Slim wall-mounted indoor units provide zone comfort control
- Dual Barrier Coating applied to the heat exchanger, vanes and fan to prevent hydrophilic and hydrophobic dirt build-up
- Optional Microparticle Filter designed to capture PM2.5
- The outdoor unit powers the indoor unit, and should a power outage occur, the system is automatically restarted when power returns
- Quiet operation
- Smart Set: recalls a preferred preset temperature setting at the touch of a button
- Built-in backup/auxiliary heater control available
- Multiple fan speed options: Quiet, Low, Medium, High, Super-high, Auto
- Multiple control options available:
  - Back-lit screen handheld remote controller (provided with the unit)
  - kumo cloud® smart device app for remote access
  - Third-party interface options
  - Wired or wireless controllers

**OUTDOOR UNIT FEATURES**

- INVERTER-driven compressor and LEV provide high efficiency and comfort while using only the energy needed to maintain maximum performance
- Hyper-heating performance offers 100% heating capacity at 5°F
- Hot-Start Technology: no cold air rush at equipment startup or when restarting after Defrost Cycle
- Quiet outdoor unit operation
- Built-in base pan heater
- Innovative DC fan motor leads to high efficiency and reliability
- Blue Fin anti-corrosion treatment applied to the outdoor unit heat exchanger for increased coil protection and longer life
  - Rated for 2,000 hours spraying time per ASTM B117 Standard

# SPECIFICATIONS: MSZ-GS12NA & MUZ-GS12NAHZ

Cooling at 95°F <sup>1</sup>	Maximum Capacity	BTU/H	13,600
	Rated Capacity	BTU/H	12,000
	Minimum Capacity	BTU/H	1,500
	Maximum Power Input	W	1,860
	Rated Power Input	W	920
	Moisture Removal	Pints/h	2.5
	Sensible Heat Factor		0.77
Heating at 47°F <sup>2</sup>	Power Factor [208V / 230V]	%	95.0 / 95.0
	Maximum Capacity	BTU/H	18,100
	Rated Capacity	BTU/H	12,300
	Minimum Capacity	BTU/H	3,600
	Maximum Power Input	W	2,020
	Rated Power Input	W	830
Heating at 17°F <sup>3</sup>	Power Factor [208V / 230V]	%	90.0 / 90.0
	Maximum Capacity	BTU/H	14,700
	Rated Capacity	BTU/H	7,600
	Maximum Power Input	W	1,820
Heating at 5°F <sup>4</sup>	Rated Power Input	W	820
	Maximum Capacity	BTU/H	12,300
Heating at 5°F <sup>4</sup>	Maximum Power Input	W	1,960
Heating at -5°F <sup>6</sup>	Maximum Capacity	BTU/H	10,510
Heating at -13°F <sup>7</sup>	Maximum Capacity	BTU/H	8,720
Efficiency	SEER2		21.7
	EER2 <sup>1</sup>		13.05
	HSPF2 [I/V]		9.6
	COP at 47°F <sup>2</sup>		4.34
	COP at 17°F at Maximum Capacity <sup>3</sup>		2.37
	COP at 5°F at Maximum Capacity <sup>4</sup>		1.84
	COP at -5°F at Maximum Capacity <sup>6</sup>		1.63
	COP at -13°F at Maximum Capacity <sup>7</sup>		1.36
Electrical	ENERGY STAR® Certified		Yes
	Voltage, Phase, Frequency		208/230, 1, 60
	Guaranteed Voltage Range	V AC	187 - 253
	Voltage: Indoor - Outdoor, S1-S2	V AC	208/230
	Voltage: Indoor - Outdoor, S2-S3	V DC	24
	Short-circuit Current Rating [SCCR]	kA	5
	Recommended Fuse/Breaker Size (Outdoor)	A	15
	Recommended Wire Size [Indoor - Outdoor]	AWG	14
Indoor Unit	Power Supply		Indoor unit is powered by the outdoor unit
	MCA	A	1.0
	Fan Motor Full Load Amperage	A	0.75
	Fan Motor Output	W	30
	Airflow Rate at Cooling, Dry	CFM	134–160–222–307–381
	Airflow Rate at Cooling, Wet	CFM	121–144–200–276–343
	Airflow Rate at Heating, Dry	CFM	134–160–222–307–390
	Sound Pressure Level [Cooling]	dB[A]	19–22–30–37–45
	Sound Pressure Level [Heating]	dB[A]	19–22–30–37–43
	Drain Pipe Size	In. [mm]	5/8 [15.88]
	Coating on Heat Exchanger		Dual Barrier Coating
	External Finish Color		Munsell 1.0Y 9.2/0.2
	Unit Dimensions	W x D x H: In. [mm]	31-7/16 x 9-1/8 x 11-5/8 [798 x 232 x 295]
	Package Dimensions	W x D x H: In. [mm]	33-1/2 x 12 x 14 [850 x 300 x 350]
Unit Weight	Lbs. [kg]	23 [10.4]	
Package Weight	Lbs. [kg]	26 [11.5]	
Indoor Unit Operating Temperature Range	Cooling Intake Air Temp [Maximum / Minimum]*	°F	90 DB, 73 WB / 67 DB, 57 WB
	Heating Intake Air Temp [Maximum / Minimum]	°F	80 DB / 70 DB

**NOTES:**

AHRI Rated Conditions

(Rated data is determined at a fixed compressor speed)

<sup>1</sup>Cooling (Indoor // Outdoor)

<sup>2</sup>Heating at 47°F (Indoor // Outdoor)

<sup>3</sup>Heating at 17°F (Indoor // Outdoor)

°F 80 DB, 67 WB // 95 DB, 75 WB

°F 70 DB, 60 WB // 47 DB, 43 WB

°F 70 DB, 60 WB // 17 DB, 15 WB

Conditions

<sup>4</sup>Heating at 5°F (Indoor // Outdoor)

°F 70 DB, 60 WB // 5 DB, 4 WB

\*Indoor/Outdoor Unit Operating Temperature Range (Cooling Air Temp [Maximum / Minimum]):

• Applications should be restricted to comfort cooling only; equipment cooling applications are not recommended for low ambient temperature conditions.

\*\*Outdoor Unit Operating Temperature Range (Cooling Thermal Lock-out / Re-start Temperatures; Heating Thermal Lock-out / Re-start Temperatures):

• System cuts out in heating mode to avoid thermistor error and automatically restarts at these temperatures.



## INDOOR UNIT ACCESSORIES: MSZ-GS12NA

Control Interface	Backup Heat Relay Kit Adapter for CN24 or CN152 on ducted models	CN24RELAY-KIT-CM3
	IT Extender for kumo station™	PAC-WHS01IE-E
	kumo station™ for kumo cloud®	PAC-WHS01HC-E
	M-Net & I/O Control Interface for M-Series	MAC-334IF-E
	Procon BACnet® and Modbus® Interface	PAC-UKPRC001-CN-1
	Thermostat Interface for 3rd Party Thermostats	PAC-US445CN-1
	USNAP Adapter for Demand Response	PAC-WHS01UP-E
Remote Sensor	Wireless Interface for kumo cloud®	PAC-USWHS002-WF-2
	Remote Temperature Sensor for MFZ, MLZ, and MSZ models	M21EAA307
Wired Remote Controller	Wireless temperature and humidity sensor for kumo cloud®	PAC-USWHS003-TH-1
	Deluxe MA Wired Remote Controller†	PAR-41MAAU
	Simple Ductless Wired Remote Controller	PAC-SDW01RC-1
	Simple MA Remote Controller	PAC-YT53CRAU-J
Wireless Remote Controller	Touch MA Wired Remote Controller	PAR-CT01MAU-SB
	kumo touch™ RedLINK™ Wireless Controller & Receiver kit	MHK2
	Lockdown Bracket for Wireless Handheld Remote Controllers	RCMKP1CB
Condensate	Blue Diamond (Advanced) Mini Condensate Pump w/ Reservoir & Sensor (208/230V) [recommended]	X87-721
	Blue Diamond (MaxiBlue Advanced) Mini Condensate Pump w/ Reservoir & Sensor (110V) up to 48,000 BTU/H [recommended]	X87-711
	Blue Diamond (MegaBlue Advanced) Condensate Pump w/ Reservoir & Sensor	X87-835
	Blue Diamond Alarm Extension Cable — 6.5 Ft.	C13-192
	Blue Diamond MultiTank — collection tank for use with multiple pumps	C21-014
	Blue Diamond Sensor Extension Cable — 15 Ft.	C13-103
	Drain Pan Level Sensor/Control	SS610E
	Fascia Kit for MicroBlue Pump, mounts the MicroBlue and sensor directly beneath indoor unit	T18-016
	Refco Condensate Pump (100-240 VAC)	GOBI-II
	Refco Condensate Pump (100-240 VAC) up to 120,000 BTU/H	COMBI
	Sauermann Condensate Pump	SI30-230
Disconnect Switch	(30A/600V/UL) [fits 2" X 4" utility box] - Black	TAZ-MS303
	(30A/600V/UL) [fits 2" X 4" utility box] - White	TAZ-MS303W
Drain Hose	Flexible Mini-Split Drain Hose	DRX-16
Filter	Anti-allergy Enzyme Filter	MAC-408FT-E

**NOTES:**

†Requires MAC-334IF-E

• M-Series EZ FIT® Recessed Ceiling Cassette, Floor-mount and Wall-mount

Allows indoor units to connect to an MA Controller:

- Deluxe MA Remote Controller
- Simple MA Controller
- Touch MA Controller

# OUTDOOR UNIT ACCESSORIES: MUZ-GS12NAHZ

Lineset	15' x 1/4" x 15' / 3/8" Lineset (Twin-Tube Insulation)	MLS143812T-15
	30' x 1/4" x 30' / 3/8" Lineset (Twin-Tube Insulation)	MLS143812T-30
	50' x 1/4" x 50' / 3/8" Lineset (Twin-Tube Insulation)	MLS143812T-50
	65' x 1/4" x 65' / 3/8" Lineset (Twin-Tube Insulation)	MLS143812T-65
Mounting Pad	Condensing Unit Mounting Pad: 24" x 42" x 3"	ULTRILITE2
Stand	18" Single Fan Stand	QSMS1801M
	24" Single Fan Stand	QSMS2401M
	Condenser Wall Bracket - Stainless Steel Finish	QSWBSS
	Outdoor Unit 3-1/4 inch Mounting Base (Pair) - Plastic	DSD-400P
	Outdoor Unit Stand — 12" High	QSMS1201M

# INDOOR UNIT DIMENSIONS: MSZ-GS12NA

Unit: inch

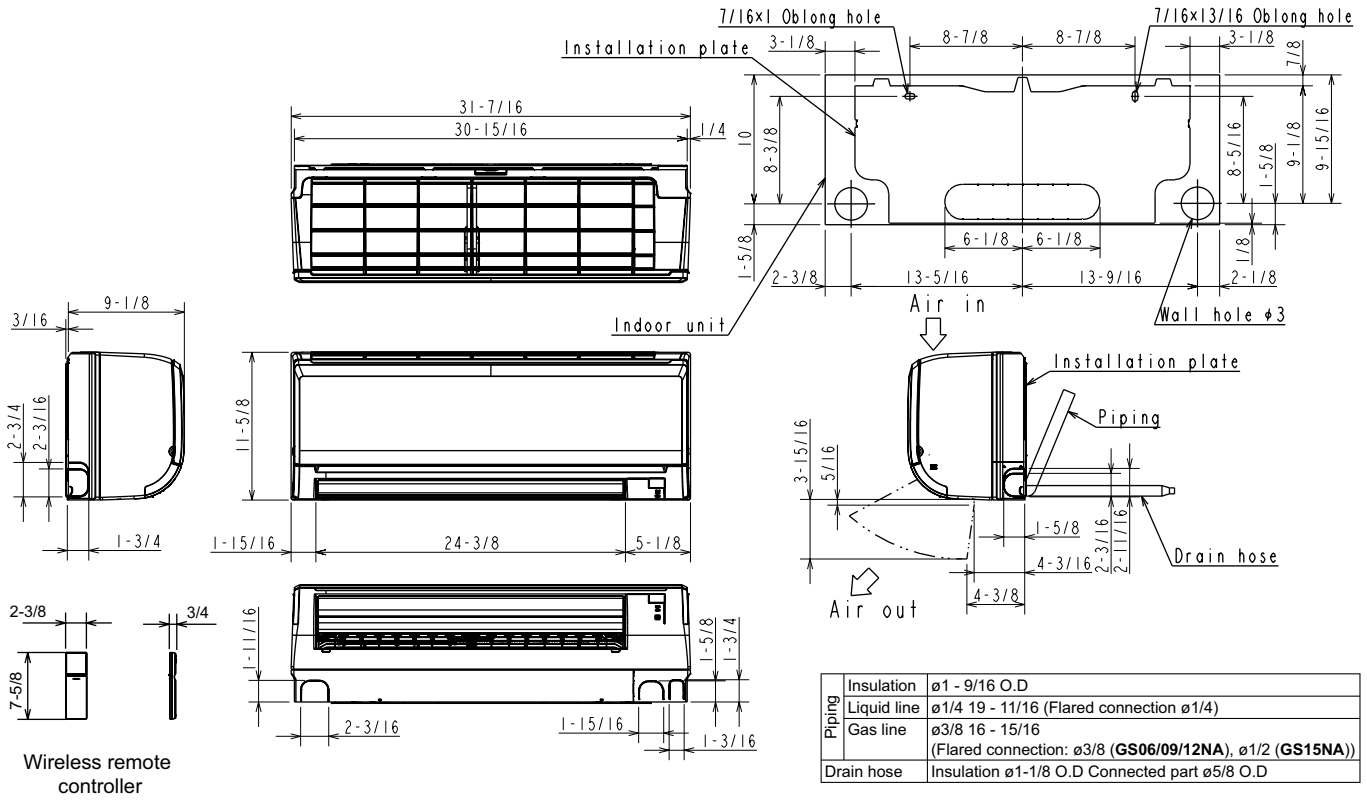

# OUTDOOR UNIT DIMENSIONS: MUZ-GS12NAHZ

Unit: inch

## REQUIRED SPACE

\*1 4 in. or more when front and sides of the unit are clear

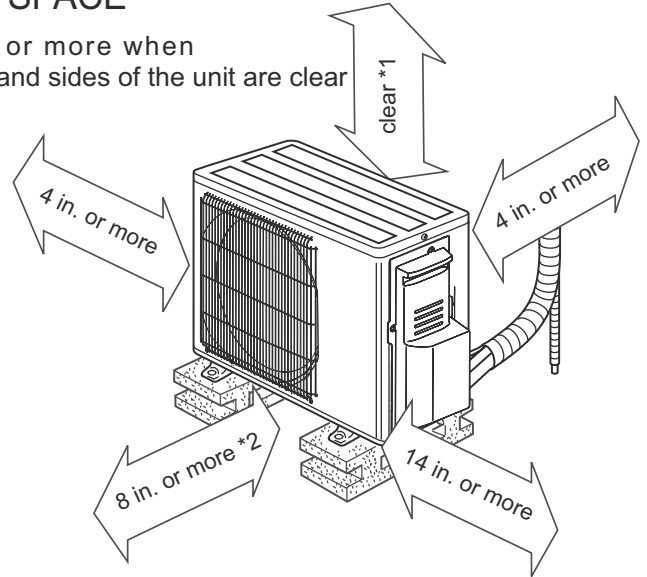

\*2 When any 2 sides of left, right and rear of the unit are clear

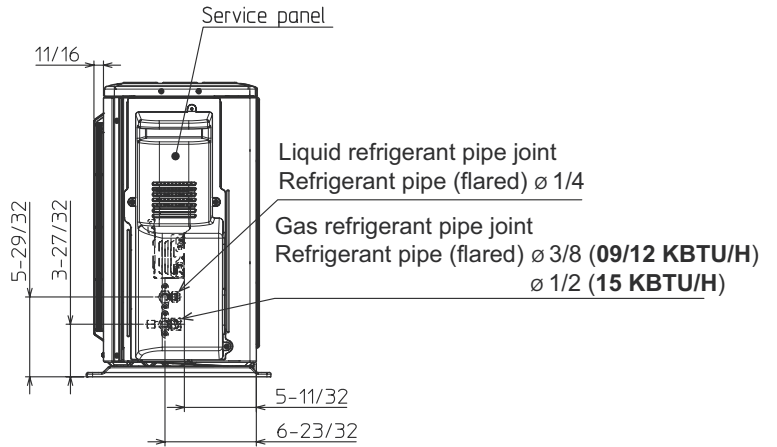
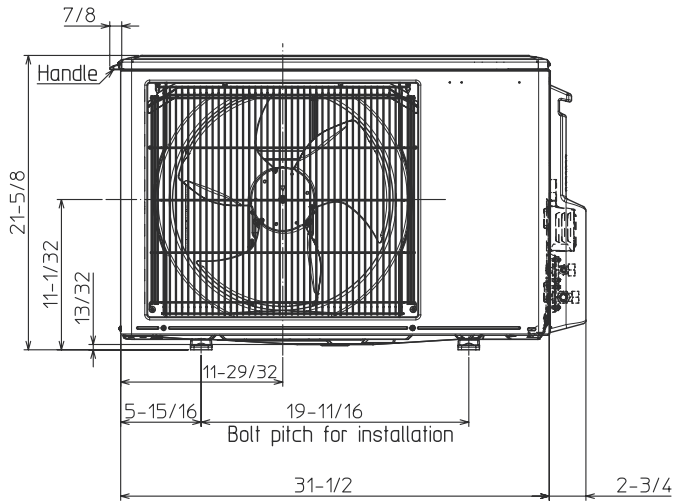
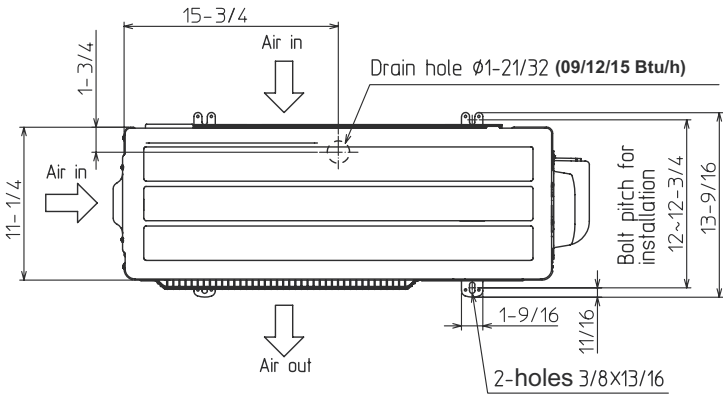

1340 Satellite Boulevard Suwanee, GA 30024  
Toll Free: 800-433-4822 www.mehvac.com

FORM# MSZ-GS12NA & MUZ-GS12NAHZ - 202406

