

MSZ-GS15NA & MUZ-GS15NAHZ
15,000 BTU/H WALL-MOUNTED INDOOR UNIT
15,000 BTU/H HYPER HEAT PUMP OUTDOOR UNIT



Job Name:

System Reference:

Date:

Indoor Unit.....MSZ-GS15NA

Outdoor Unit.....MUZ-GS15NAHZ



INDOOR UNIT FEATURES

- Slim wall-mounted indoor units provide zone comfort control
- Dual Barrier Coating applied to the heat exchanger, vanes and fan to prevent hydrophilic and hydrophobic dirt build-up
- Optional Microparticle Filter designed to capture PM2.5
- The outdoor unit powers the indoor unit, and should a power outage occur, the system is automatically restarted when power returns
- Quiet operation
- Smart Set: recalls a preferred preset temperature setting at the touch of a button
- Built-in backup/auxiliary heater control available
- Multiple fan speed options: Quiet, Low, Medium, High, Super-high, Auto
- Multiple control options available:
 - Back-lit screen handheld remote controller (provided with the unit)
 - kumo cloud® smart device app for remote access
 - Third-party interface options
 - Wired or wireless controllers

OUTDOOR UNIT FEATURES

- INVERTER-driven compressor and LEV provide high efficiency and comfort while using only the energy needed to maintain maximum performance
- Hyper-heating performance offers 100% heating capacity at 5°F
- Hot-Start Technology: no cold air rush at equipment startup or when restarting after Defrost Cycle
- Quiet outdoor unit operation
- Built-in base pan heater
- Innovative DC fan motor leads to high efficiency and reliability
- Blue Fin anti-corrosion treatment applied to the outdoor unit heat exchanger for increased coil protection and longer life
 - Rated for 2,000 hours spraying time per ASTM B117 Standard

SPECIFICATIONS: MSZ-GS15NA & MUZ-GS15NAHZ

| | | | |
|---|---|--|--|
| Cooling at 95°F ¹ | Maximum Capacity | BTU/H | 18,200 |
| | Rated Capacity | BTU/H | 14,000 |
| | Minimum Capacity | BTU/H | 3,100 |
| | Maximum Power Input | W | 2,020 |
| | Rated Power Input | W | 1,100 |
| | Moisture Removal | Pints/h | 2.5 |
| | Sensible Heat Factor | | 0.80 |
| Heating at 47°F ² | Maximum Capacity | BTU/H | 20,900 |
| | Rated Capacity | BTU/H | 14,000 |
| | Minimum Capacity | BTU/H | 4,800 |
| | Maximum Power Input | W | 2,030 |
| | Rated Power Input | W | 1,140 |
| | Power Factor [208V / 230V] | % | 95.0 / 95.0 |
| Heating at 17°F ³ | Maximum Capacity | BTU/H | 16,800 |
| | Rated Capacity | BTU/H | 8,700 |
| | Maximum Power Input | W | 2,020 |
| Heating at 5°F ⁴ | Maximum Capacity | BTU/H | 14,000 |
| | Maximum Power Input | W | 2,150 |
| Heating at -5°F ⁶ | Maximum Capacity | BTU/H | 11,910 |
| Heating at -13°F ⁷ | Maximum Capacity | BTU/H | 9,820 |
| Efficiency | SEER2 | | 21.0 |
| | EER2 ¹ | | 12.75 |
| | HSPF2 [I/V] | | 9.4 |
| | COP at 47°F ² | | 3.6 |
| | COP at 17°F at Maximum Capacity ³ | | 2.44 |
| | COP at 5°F at Maximum Capacity ⁴ | | 1.91 |
| | COP at -5°F at Maximum Capacity ⁶ | | 1.62 |
| | COP at -13°F at Maximum Capacity ⁷ | | 1.33 |
| ENERGY STAR® Certified | | Yes | |
| Electrical | Voltage, Phase, Frequency | | 208/230, 1, 60 |
| | Guaranteed Voltage Range | V AC | 187 - 253 |
| | Voltage: Indoor - Outdoor, S1-S2 | V AC | 208/230 |
| | Voltage: Indoor - Outdoor, S2-S3 | V DC | 24 |
| | Short-circuit Current Rating [SCCR] | kA | 5 |
| | Recommended Fuse/Breaker Size (Outdoor) | A | 15 |
| | Recommended Wire Size [Indoor - Outdoor] | AWG | 14 |
| Power Supply | | Indoor unit is powered by the outdoor unit | |
| Indoor Unit | MCA | A | 1.0 |
| | Fan Motor Full Load Amperage | A | 0.75 |
| | Fan Motor Output | W | 30 |
| | Airflow Rate at Cooling, Dry | CFM | 191–253–316–400–504 |
| | Airflow Rate at Cooling, Wet | CFM | 172–228–285–360–454 |
| | Airflow Rate at Heating, Dry | CFM | 191–231–285–348–437 |
| | Sound Pressure Level [Cooling] | dB[A] | 26–32–38–44–49 |
| | Sound Pressure Level [Heating] | dB[A] | 26–30–35–40–46 |
| | Drain Pipe Size | In. [mm] | 5/8 [15.88] |
| | Coating on Heat Exchanger | | Dual Barrier Coating |
| | External Finish Color | | Munsell 1.0Y 9.2/0.2 |
| | Unit Dimensions | W x D x H: In. [mm] | 31-7/16 x 9-1/8 x 11-5/8 [798 x 232 x 295] |
| | Package Dimensions | W x D x H: In. [mm] | 33-1/2 x 12 x 14 [850 x 300 x 350] |
| Unit Weight | Lbs. [kg] | 23 [10.4] | |
| Package Weight | Lbs. [kg] | 26 [11.5] | |
| Indoor Unit Operating Temperature Range | Cooling Intake Air Temp [Maximum / Minimum]* | °F | 90 DB, 73 WB / 67 DB, 57 WB |
| | Heating Intake Air Temp [Maximum / Minimum] | °F | 80 DB / 70 DB |

NOTES:

AHRI Rated Conditions

(Rated data is determined at a fixed compressor speed)

¹Cooling (Indoor // Outdoor)

²Heating at 47°F (Indoor // Outdoor)

³Heating at 17°F (Indoor // Outdoor)

°F 80 DB, 67 WB // 95 DB, 75 WB

°F 70 DB, 60 WB // 47 DB, 43 WB

°F 70 DB, 60 WB // 17 DB, 15 WB

Conditions

⁴Heating at 5°F (Indoor // Outdoor)

°F 70 DB, 60 WB // 5 DB, 4 WB

*Indoor/Outdoor Unit Operating Temperature Range (Cooling Air Temp [Maximum / Minimum]):

- Applications should be restricted to comfort cooling only; equipment cooling applications are not recommended for low ambient temperature conditions.

**Outdoor Unit Operating Temperature Range (Cooling Thermal Lock-out / Re-start Temperatures; Heating Thermal Lock-out / Re-start Temperatures):

- System cuts out in heating mode to avoid thermistor error and automatically restarts at these temperatures.

SPECIFICATIONS: MSZ-GS15NA & MUZ-GS15NAHZ

| | | | |
|--|--|---------------------------------------|--|
| Outdoor Unit | MCA | A | 10.0 |
| | MOCP | A | 15 |
| | Fan Motor Full Load Amperage | A | 0.5 |
| | Airflow Rate [Cooling / Heating] | CFM | 1166 / 1152 |
| | Refrigerant Control | | LEV |
| | Defrost Method | | Reverse Cycle |
| | Coating on Heat Exchanger | | Blue Fin Coating |
| | Sound Pressure Level, Cooling ¹ | dB(A) | 49 |
| | Sound Pressure Level, Heating ² | dB(A) | 51 |
| | Compressor Type | | DC inverter driven Twin Rotary |
| | Compressor Model | | SNB140FQUMT |
| | Compressor Rated Load Amps | A | 7.4 |
| | Compressor Locked Rotor Amps | A | 9.2 |
| | Compressor Oil [Type // Charge] | oz. | FV50S // 11.8 |
| | External Finish Color | | Munsell 3Y 7.8/1/1 |
| | Base Pan Heater | | Built-in |
| | Unit Dimensions | W x D x H: In. [mm] | 31-1/2 x 11-1/4 x 21-5/8 [800 x 285 x 550] |
| | Package Dimensions | W x D x H: In. [mm] | 37 x 15 x 24-1/2 [940 x 380 x 630] |
| | Unit Weight | Lbs. [kg] | 85 [38] |
| | Package Weight | Lbs. [kg] | 92 [42] |
| | Outdoor Unit Operating Temperature Range | Cooling Air Temp [Maximum / Minimum]* | °F |
| Cooling Thermal Lock-out / Re-start Temperatures** | | °F | -4 / 0 |
| Heating Air Temp [Maximum / Minimum] | | °F | 75 DB, 65 WB / -13 DB, -14 WB |
| Heating Thermal Lock-out / Re-start Temperatures** | | °F | -22 / -14 |
| Refrigerant | Type | | R410A |
| | Pre-Charged Refrigerant Amount | Lbs, oz | 2.0, 9.0 |
| | Maximum Pre-Charged Piping Length | Ft. [m] | 25.0 [7.5] |
| | Additional Refrigerant Charge Per Additional Piping Length | oz./Ft. [g/m] | 1.08 [20] |
| Piping | Gas Pipe Size O.D. [Flared] | In.[mm] | 1/2 [12.70] |
| | Liquid Pipe Size O.D. [Flared] | In.[mm] | 1/4 [6.35] |
| | Maximum Piping Length | Ft. [m] | 65 [20] |
| | Maximum Height Difference | Ft. [m] | 40 [12] |
| | Maximum Number of Bends | | 10 |

NOTES:

AHRI Rated Conditions

(Rated data is determined at a fixed compressor speed)

| | | |
|--|----|------------------------------|
| ¹ Cooling (Indoor // Outdoor) | °F | 80 DB, 67 WB // 95 DB, 75 WB |
| ² Heating at 47°F (Indoor // Outdoor) | °F | 70 DB, 60 WB // 47 DB, 43 WB |
| ³ Heating at 17°F (Indoor // Outdoor) | °F | 70 DB, 60 WB // 17 DB, 15 WB |

Conditions

| | | |
|---|----|----------------------------|
| ⁴ Heating at 5°F (Indoor // Outdoor) | °F | 70 DB, 60 WB // 5 DB, 4 WB |
|---|----|----------------------------|

*Indoor/Outdoor Unit Operating Temperature Range (Cooling Air Temp [Maximum / Minimum]):

- Applications should be restricted to comfort cooling only; equipment cooling applications are not recommended for low ambient temperature conditions.

**Outdoor Unit Operating Temperature Range (Cooling Thermal Lock-out / Re-start Temperatures; Heating Thermal Lock-out / Re-start Temperatures):

- System cuts out in heating mode to avoid thermistor error and automatically restarts at these temperatures.

INDOOR UNIT ACCESSORIES: MSZ-GS15NA

| | | |
|----------------------------|---|-------------------|
| Control Interface | Backup Heat Relay Kit Adapter for CN24 or CN152 on ducted models | CN24RELAY-KIT-CM3 |
| | IT Extender for kumo station™ | PAC-WHS01IE-E |
| | kumo station™ for kumo cloud® | PAC-WHS01HC-E |
| | M-Net & I/O Control Interface for M-Series | MAC-334IF-E |
| | Procon BACnet® and Modbus® Interface | PAC-UKPRC001-CN-1 |
| | USNAP Adapter for Demand Response | PAC-WHS01UP-E |
| Remote Sensor | Wireless Interface for kumo cloud® | PAC-USWHS002-WF-2 |
| | Remote Temperature Sensor for MFZ, MLZ, and MSZ models | M21EAA307 |
| Wired Remote Controller | Wireless temperature and humidity sensor for kumo cloud® | PAC-USWHS003-TH-1 |
| | Deluxe MA Wired Remote Controller† | PAR-41MAAU |
| | Simple Ductless Wired Remote Controller | PAC-SDW01RC-1 |
| | Simple MA Remote Controller | PAC-YT53CRAU-J |
| Wireless Remote Controller | Touch MA Wired Remote Controller | PAR-CT01MAU-SB |
| | kumo touch™ RedLINK™ Wireless Controller & Receiver kit | MHK2 |
| | Lockdown Bracket for Wireless Handheld Remote Controllers | RCMKP1CB |
| Condensate | Blue Diamond (Advanced) Mini Condensate Pump w/ Reservoir & Sensor (208/230V) [recommended] | X87-721 |
| | Blue Diamond (MaxiBlue Advanced) Mini Condensate Pump w/ Reservoir & Sensor (110V) up to 48,000 BTU/H [recommended] | X87-711 |
| | Blue Diamond (MegaBlue Advanced) Condensate Pump w/ Reservoir & Sensor | X87-835 |
| | Blue Diamond Alarm Extension Cable — 6.5 Ft. | C13-192 |
| | Blue Diamond MultiTank — collection tank for use with multiple pumps | C21-014 |
| | Blue Diamond Sensor Extension Cable — 15 Ft. | C13-103 |
| | Drain Pan Level Sensor/Control | SS610E |
| | Fascia Kit for MicroBlue Pump, mounts the MicroBlue and sensor directly beneath indoor unit | T18-016 |
| | Saueremann Condensate Pump | SI30-230 |
| Disconnect Switch | (30A/600V/UL) [fits 2" X 4" utility box] - Black | TAZ-MS303 |
| | (30A/600V/UL) [fits 2" X 4" utility box] - White | TAZ-MS303W |
| Filter | Anti-allergy Enzyme Filter | MAC-408FT-E |

NOTES:

†Requires MAC-334IF-E

- M-Series EZ FIT® Recessed Ceiling Cassette, Floor-mount and Wall-mount
Allows indoor units to connect to an MA Controller:
Deluxe MA Remote Controller
Simple MA Controller
Touch MA Controller

OUTDOOR UNIT ACCESSORIES: MUZ-GS15NAHZ

| | | |
|--------------|--|---------------|
| Lineset | 15' x 1/4" x 15' / 3/8" Lineset (Twin-Tube Insulation) | MLS143812T-15 |
| | 30' x 1/4" x 30' / 3/8" Lineset (Twin-Tube Insulation) | MLS143812T-30 |
| | 50' x 1/4" x 50' / 3/8" Lineset (Twin-Tube Insulation) | MLS143812T-50 |
| | 65' x 1/4" x 65' / 3/8" Lineset (Twin-Tube Insulation) | MLS143812T-65 |
| Mounting Pad | Condensing Unit Mounting Pad: 24" x 42" x 3" | ULTRILITE2 |
| Stand | 18" Single Fan Stand | QSMS1801M |
| | 24" Single Fan Stand | QSMS2401M |
| | Condenser Wall Bracket - Stainless Steel Finish | QSWBSS |
| | Outdoor Unit 3-1/4 inch Mounting Base (Pair) - Plastic | DSD-400P |
| | Outdoor Unit Stand — 12" High | QSMS1201M |

INDOOR UNIT DIMENSIONS: MSZ-GS15NA

Unit: inch

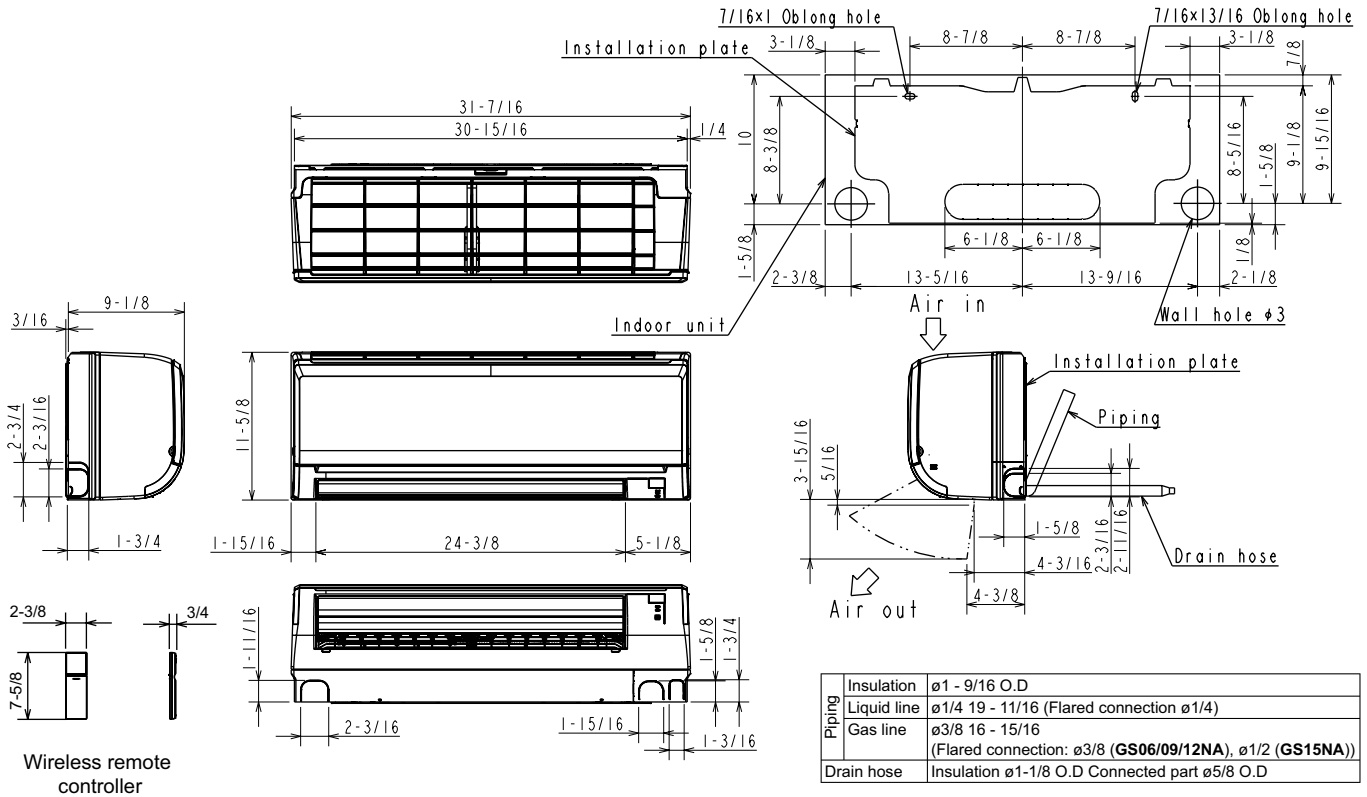

OUTDOOR UNIT DIMENSIONS: MUZ-GS15NAHZ

Unit: inch

REQUIRED SPACE

*1 4 in. or more when front and sides of the unit are clear

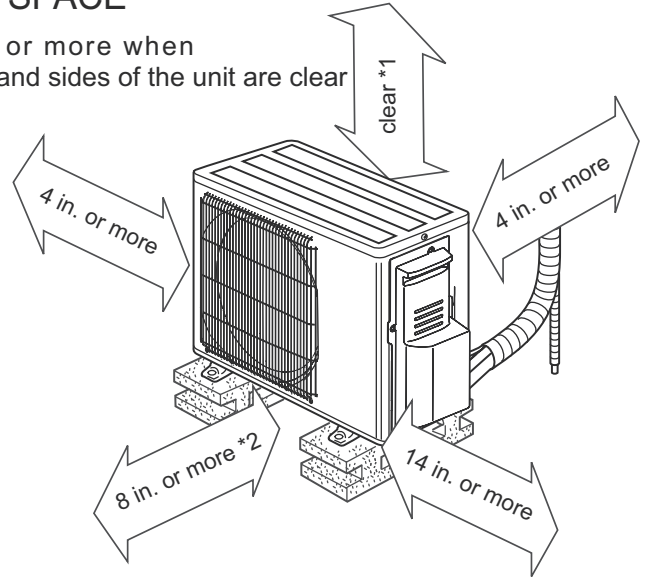

*2 When any 2 sides of left, right and rear of the unit are clear

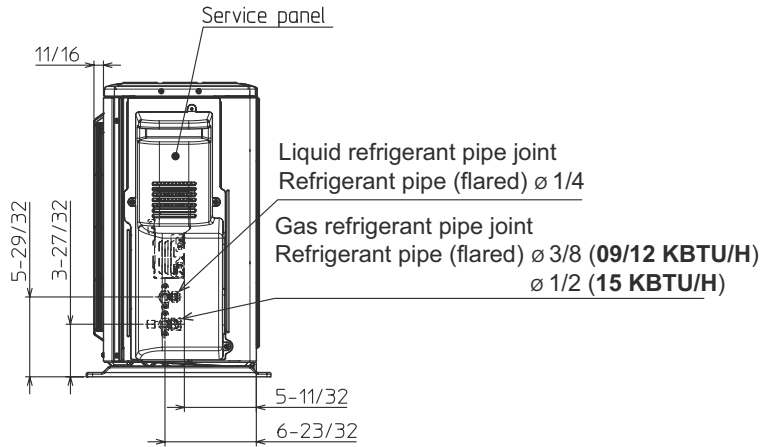
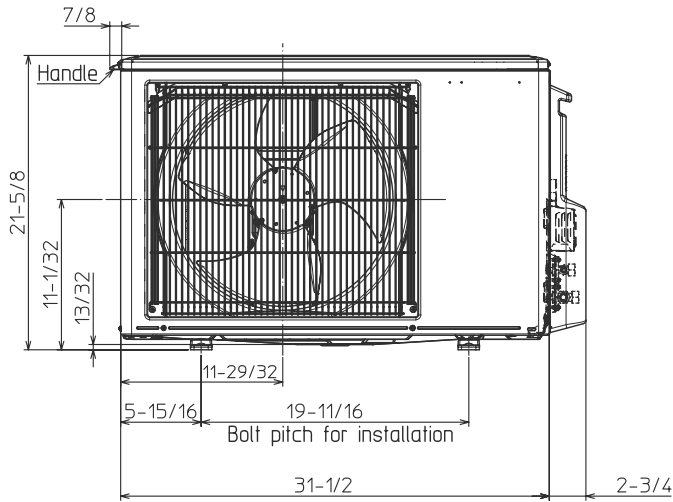
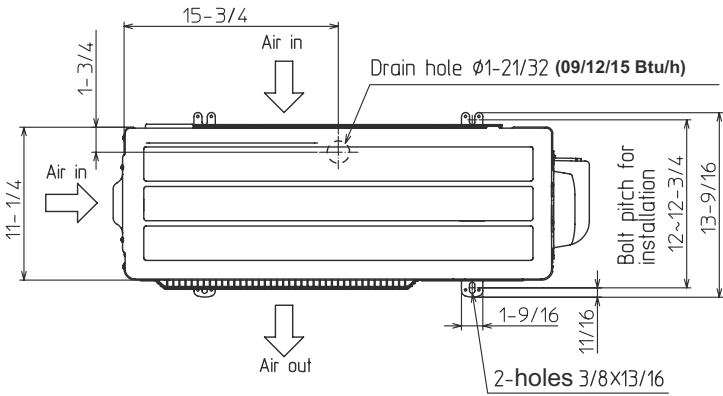

1340 Satellite Boulevard Suwanee, GA 30024
Toll Free: 800-433-4822 www.mehvac.com

FORM# MSZ-GS15NA & MUZ-GS15NAHZ - 202406

