

# INSTALLATION INSTRUCTIONS

## FOR REPLACEMENT COILS USED IN AIR HANDLERS

(-)CH: featuring Industry-Standard R-410A  Refrigerant



**RECOGNIZE THIS SYMBOL AS AN INDICATION OF IMPORTANT SAFETY INFORMATION!**

### **WARNING**

These instructions are intended as an aid to qualified licensed service personnel for proper installation, adjustment and operation of this unit. Read these instructions thoroughly before attempting installation or operation. Failure to follow these instructions may result in improper installation, adjustment, service or maintenance possibly resulting in fire, electrical shock, property damage, personal injury or death.



**ISO 9001:2008**  
Certificate Number: 30164

**DO NOT DESTROY THIS MANUAL**  
**PLEASE READ CAREFULLY AND KEEP IN A SAFE PLACE FOR FUTURE REFERENCE BY A SERVICEMAN**



**FIGURE 1**  
MODEL NUMBER EXPLANATION

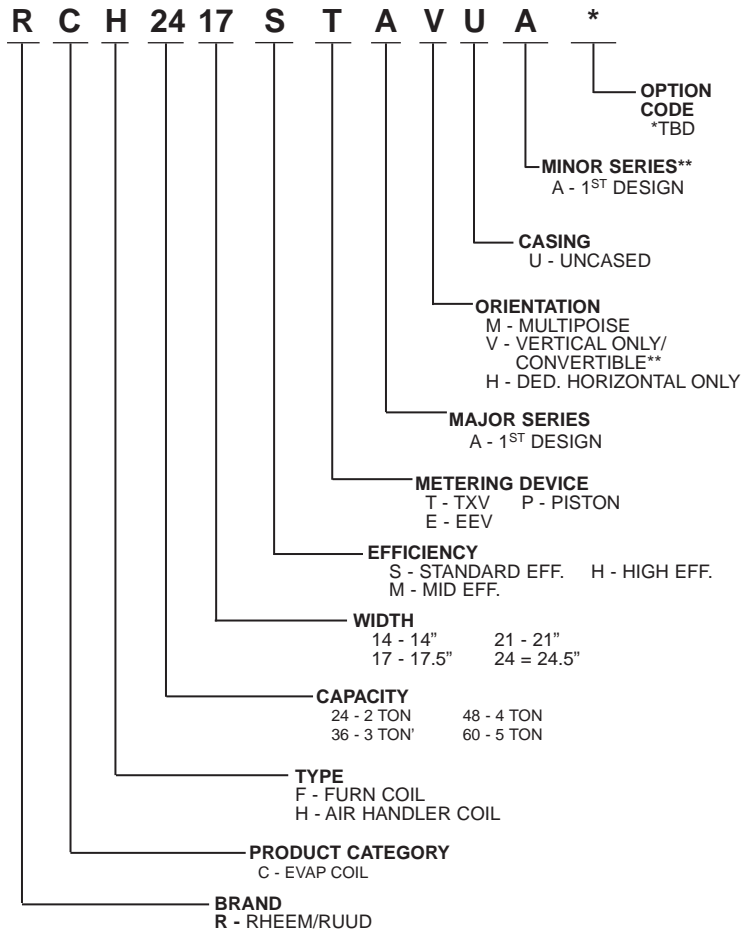

"All replacement coils for HM and AU air handler applications will be HU."  
\*\*Convertible to horizontal using parts from original coil or using RXHH horizontal adapter kit.

## GENERAL

(-)CH is a replacement only uncased coil. (-)CH-replacement coils are used only in (-)HKL, (-)HLL, (-)HLP, (-)HML, (-)HPL, (-)HPN, (-)HSL, (-)H1P, (-)H1T, (-)H2T, (-)H1V, and (-)H2V R410A air handlers.

For horizontal applications, a horizontal drip shield and water management parts (see Figure 2) must be installed to catch excess condensate drainage.

### COIL END SHIELDS

All uncased replacement coils come equipped from the factory with sheet metal shields at the front and rear of the coil. The purpose of these shields is to isolate the aluminum tubing from copper residue left on the foil insulation by the original copper tube coil. Copper residue or copper oxide in contact with the aluminum tubing in the presence of moisture will result in galvanic corrosion and leaks in the aluminum tube at the contact point. The shields must be in place on the coil when replacing a copper tube coil to prevent the galvanic corrosion.

**FIGURE 2**

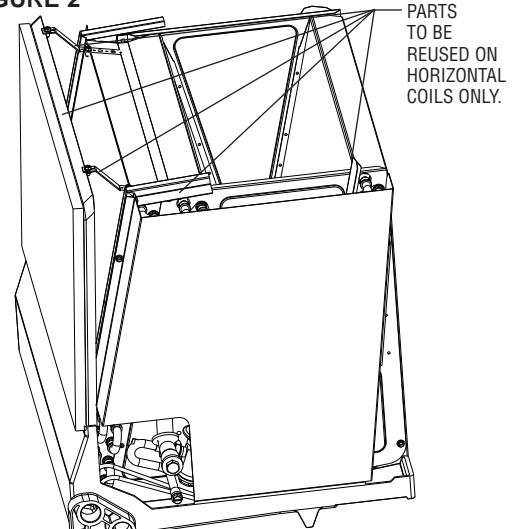

ST-A1213

**TABLE 1**  
R-410A UNCASED COILS: (-)CSL- ACCESSORY INFORMATION

Replacement R-410A Uncased Coil	Original Coil	Horizontal Adapter Kit Model Number
RCH2417STAVUA	RCSL-HU2417CU	RXHH-A02
RCH2421MTAVUA	RCSL-HU2621CU	RXHH-A03
RCH3617STAVUA	RCSL-HU3617CU	RXHH-A03
RCH3621STAVUA	RCSL-HU3621CU	RXHH-A03
RCH3621MTAVUA	RCSL-HU3821CU	RXHH-A04
RCH3624MTAVUA	RCSL-HU3824CU	RXHH-A04
RCH4821STAVUA	RCSL-HU4821CU	RXHH-A04
RCH4824STAVUA	RCSL-HU4824CU	RXHH-A04
RCH6024STAVUA	RCSL-HU6024CU	RXHH-A05
RCH2421HTAVUA	RCSN-HU2421CU	RXHH-A03
RCH3624HTAVUA	RCSN-HU3624CU	RXHH-A05
RCH4824HTAVUA	RCSN-HU4824CU	RXHH-A05
RCH6024HTAVUA	RCSN-HU6024CU	RXHH-A05
RCH2417SPAVUA	RCSP-HU2417CU	RXHH-A02
RCH3617SPAVUA	RCSP-HU3617CU	RXHH-A03
RCH4821SPAVUA	RCSP-HU4821CU	RXHH-A04

**FIGURE 3  
BULB LOCATION**

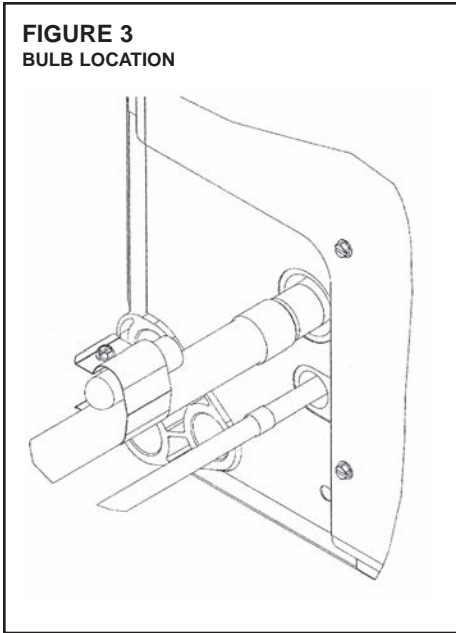

**FIGURE 4  
BULB LOCATION**

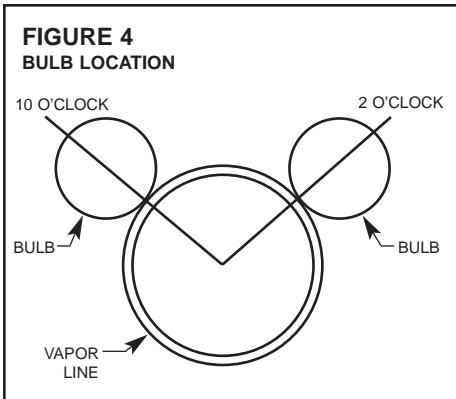

## REFRIGERANT CONNECTIONS

Keep the coil connections sealed until refrigerant connections are to be made. See the Installation Instructions for the outdoor unit for details on line sizing, tubing installation, and charging information.

Coil is shipped with a low (5 - 10 PSIG) pressure charge of dry nitrogen. Evacuate the system before charging with refrigerant.

Install refrigerant tubing so that it does not block service access to the front of the unit.

Nitrogen should flow through the refrigerant lines while brazing.

Use a brazing shield to protect the cabinet's paint from being damaged by torch flames.

After the refrigerant connections are made, seal the gap around the connections with pressure sensitive gasket. If necessary, cut the gasket into two pieces for a better seal.

## TEV SENSING BULB

**IMPORTANT:** DO NOT perform any soldering with the TEV bulb attached to any line.

After soldering operations have been completed, clamp the TEV bulb securely on the suction line at the 10 to 2 o'clock position with the strap provided in the parts bag.

Insulate the TEV sensing bulb and suction line with the provided pressure sensitive insulation (size 4" x 7") and secure with provided wire ties.

**IMPORTANT:** TEV sensing bulb should be located on a horizontal section of copper suction line, just outside of coil box. The copper sensing bulb must never be placed on any aluminum tube as this will result in galvanic corrosion and eventual failure of the aluminum tube.

## FLOW CHECK PISTON

### ⚠ NOTICE

**FOR PROPER SYSTEM OPERATION, IT MAY BE NECESSARY TO REPLACE THE PISTON INSTALLED IN THE INDOOR COIL. CHECK THE SERVICE VALVES ON THIS UNIT TO SEE IF A NOTICE TAG ALONG WITH A PLASTIC BAG CONTAINING A PISTON IS ATTACHED. IF ONE IS PRESENT A CHANGE OF THE PISTON IS REQUIRED. FAILURE TO CHANGE THE PISTON CAN RESULT IN IMPROPER PERFORMANCE OF THE SYSTEM.**

The flow check piston is a multi-purpose device. With flow into the compression nut end from the liquid line, the piston is in a check position and acts as the expansion device with flow through the metering orifice in the center of the piston. The "O" ring on the end of the piston prevents refrigerant from bypassing the metering orifice. Flow from the metering orifice is centered into a distributor which serves to evenly distribute refrigerant to the evaporator circuits. With flow in the reverse direction (direction of arrows on the distributor body), the piston is forced off the seat and liquid from the condenser is allowed to free flow around the piston.

It is essential that the heat pump indoor and outdoor sections be properly matched. Use only matched components as shown in sales specification sheets.

A piston size that is too small will cause starving and one that is too large will cause flooding. In either case, system performance, reliability and charge balance (heating and cooling) will be unacceptable.

Change the piston in the distributor on the indoor coil before installing the coil and charging the system following the procedure below:

- Using a back-up wrench on the distributor body, loosen the compression nut to gain access to the piston.
- Using the wire provided with replacement pistons, run (hooked end) through hole in piston.
- Hook nose end of piston and lift gently from distributor body.
- Replace piston with one of proper size (see Table 4), install piston with gasket end of piston in distributor. Do not force piston into distributor.
- **NOTE:** With piston in distributor, seal end should be down and should not be seen looking in end of distributor. Piston must be free to rotate and move up and down. Make sure piston is free to move in distributor body.
- Insure distributor gasket is located properly in the distributor body.

- Replace compression nut using back-up wrench on distributor body. Torque compression nut end with 8 to 10 ft. lbs.
- Original piston size is stamped on outside of distributor body. Remove new piston size label from poly bag new piston came in and install new size label on outside of distributor tube.
- Check fittings for leaks after installation, evacuation and charging is complete.

**IMPORTANT:** Do not attempt to drill pistons to size in the field. Metering holes have a special chamfered inlet and cannot be modified.

**IMPORTANT:** Do not replace the neoprene "O" ring on the piston with any type of seal. Contact the parts department for the exactly replacement of "O" ring.

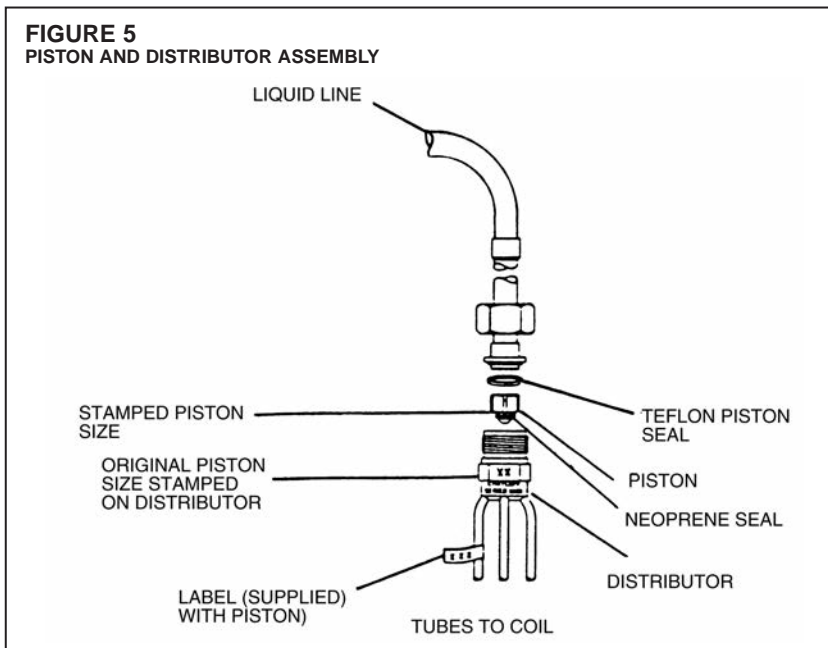

**TABLE 2**

R-22 TXV CONVERSION KITS (TO BE USED TO CONVERT R-410A COIL TO OPERATE WITH R-22)

AIR HANDLER CROSS REFERENCE CHART			
ORIGINAL AIR HANDLER	ORIGINAL AIR HANDLER COIL	RECOMMENDED ALUMINUM TUBE REPLACEMENT COIL (R-410A)	R-22 TXV CONVERSION KIT MODEL NO.
RHSA-**1817	RCSA-**2417	RCH2417STA	RXCT-HBA
RHSA-**2417	RCSA-**2417	RCH2417STA	RXCT-HBA
RHLA-**2417	RCSA-**2417	RCH2417STA	RXCT-HBA
RHSA-**3017	RCSA-**3617	RCH3617STA	RXCT-HBB
RHSA-**3617	RCSA-**3617	RCH3617STA	RXCT-HBB
RHLA-**3617	RCSA-**3617	RCH3617STA	RXCT-HBB
RHSA-**3621	RCSA-**3621	RCH3621STA, RCH2421MTA, or RCH2421HTA	RXCT-HBB
RHSA-**4221	RCSA-**4821	RCH4821STA or RCH3621MTA	RXCT-HBC
RHSA-**4821	RCSA-**4821	RCH4821STA or RCH3621MTA	RXCT-HBC
RHLA-**4821	RCSA-**4821	RCH4821STA or RCH3621MTA	RXCT-HBC
RHSA-**4824	RCSA-**4824	RCH4824STA or RCH4824MTA	RXCT-HBC
RHLA-**4824	RCSA-**4824	RCH4824STA or RCH4824MTA	RXCT-HBC
RHSA-**6024	RCSA-**6024	RCH6024STA, RCH6024HTA, RCH4824HTA, or RCH3624HTA	RXCT-HBD
RHLA-**6024	RCSA-**6024	RCH6024STA, RCH6024HTA, RCH4824HTA, or RCH3624HTA	RXCT-HBD

\*\*= AU, HM, OR HU