

71449-00001.B

LF Actuators with HTCCV and CCV

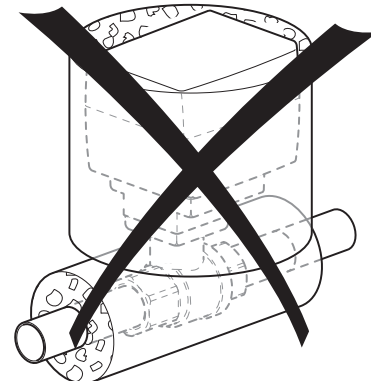

Spring Return Actuator with On/Off, Floating Point and -SR

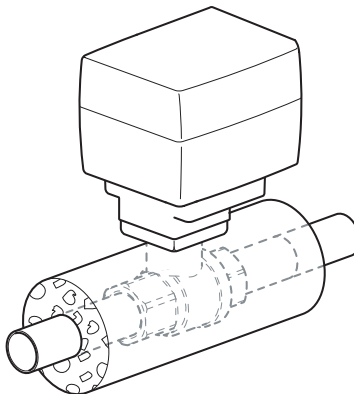
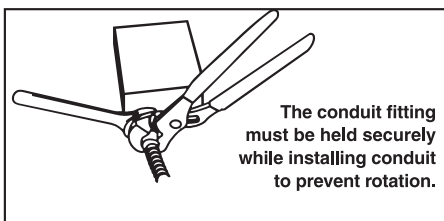
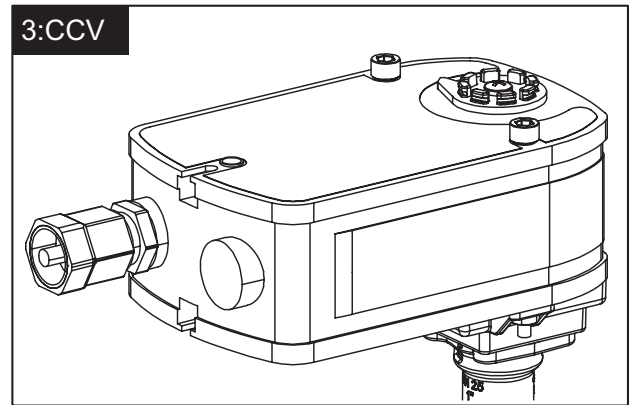
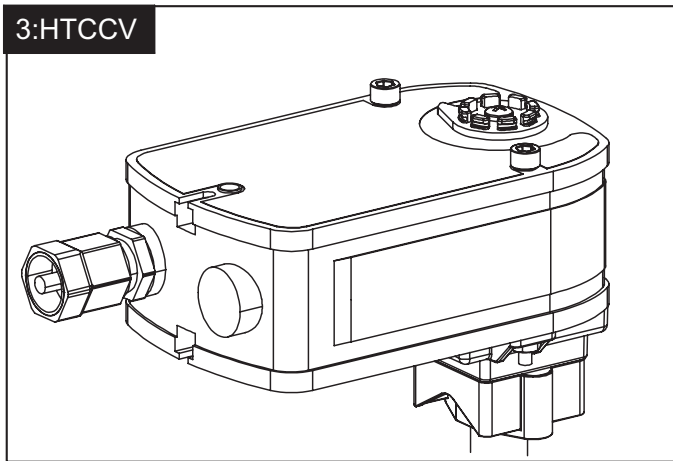
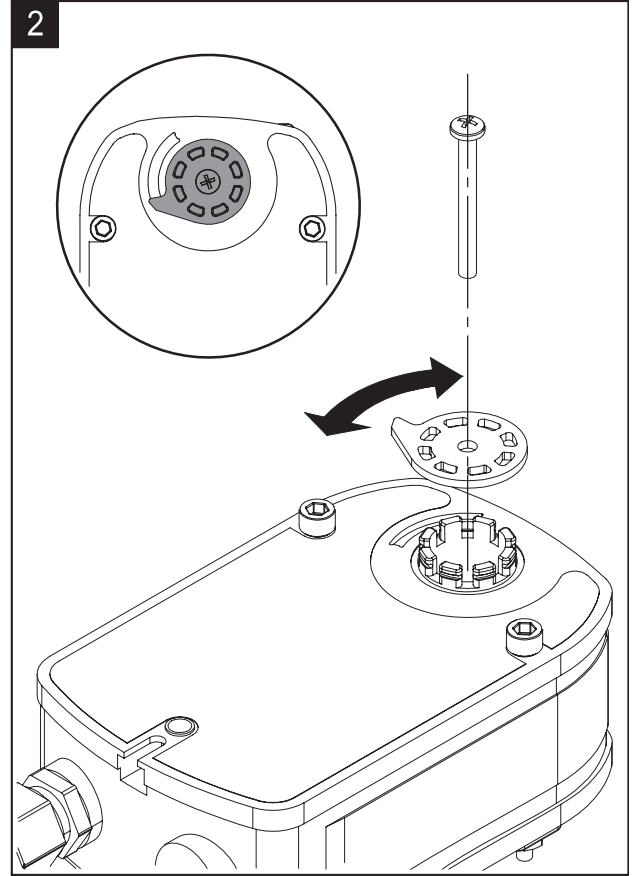
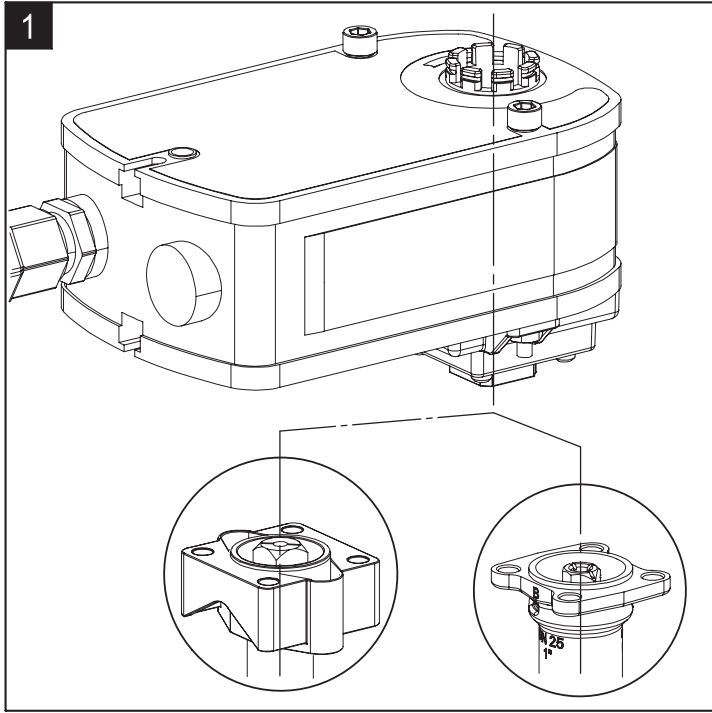
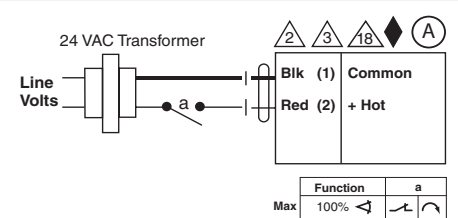

On/Off

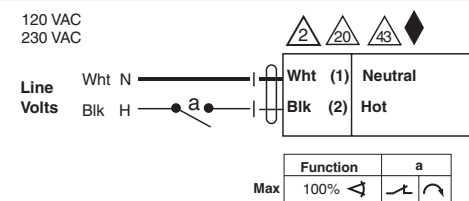

24 VAC up to 240 VAC

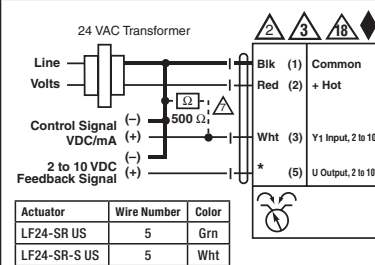

VDC / 4 to 20 mA

Spring Return Actuator with MFT

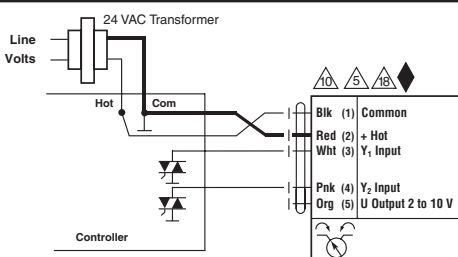

Triac Sink

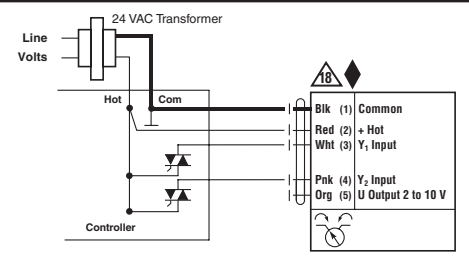

Triac Source

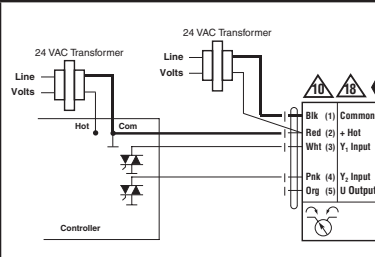

Triac Sink with Separate Transformer

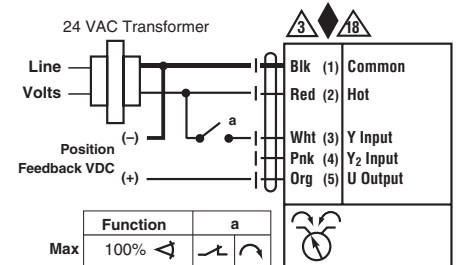

On/Off

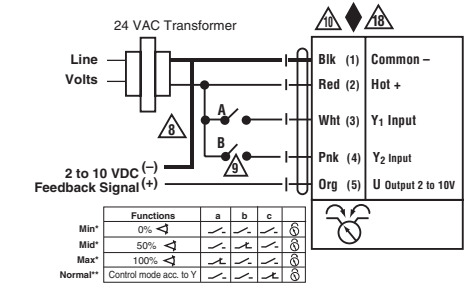

Floating Point

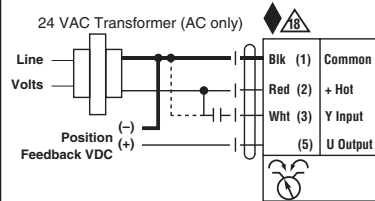

PWM

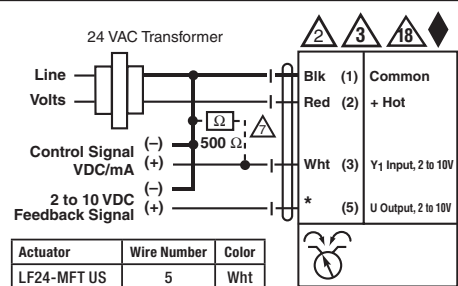

VDC / 4 to 20 mA

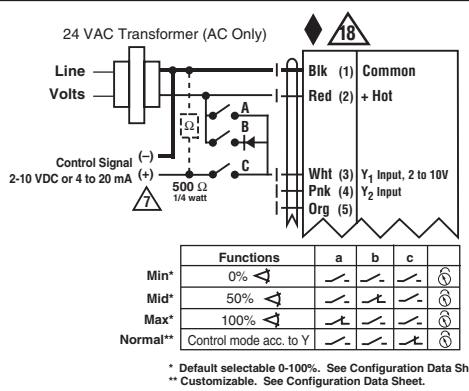

Override Control Min, Mid, Max Postions

- Notes:**
- ◆ Meets cULus requirements without the need of an electrical ground connection
 - Ⓐ Actuators with appliance cables are numbered.
 - Ⓐ Actuators may be connected in parallel. Power consumption and input impedance must be observed.
 - Ⓐ Actuators may also be powered by 24 VDC.
 - Ⓐ Only connect common to neg. (-) leg of control circuits.
 - Ⓐ A 500 Ω resistor converts the 4 to 20 mA control signal to 2 to 10 VDC.
 - Ⓐ Control signal may be pulsed from either the Hot (Source) or Common (Sink) 24 VAC line.
 - Ⓐ Contact closures A & B also can be triacs. A & B should both be closed for the triac source and open for triac sink.
 - Ⓐ For triac sink the Common connection from the actuator must be connected to the Hot connection of the controller. Position feedback cannot be used with a triac sink controller. The actuator internal common reference is not compatible.
 - Ⓐ Actuators may be connected in parallel if not mechanically mounted to the same shaft. Power consumption and input impedance must be observed.
 - Ⓐ Actuators with plenum rated cable do not have numbers on wires; use color codes instead.
 - Ⓐ All 120 VAC, 230 VAC, and UP actuators use appliance rated cables.
 - Ⓐ UP models use "L" instead of "H" on #2 wire.

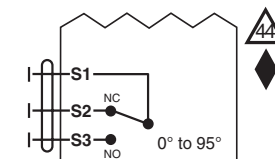

Auxiliary Switches

- GRN Green
- Verde Verde
- Verde Verde
- ORG Orange
- Anaranjado Orange
- ORANGE Orange
- Alaranjado Alaranjado
- PNK Pink
- Rosado Rosado
- Rosa Rosa
- Cor-de-ros Cor-de-ros
- WHT White
- Bianco Bianco
- Bianco Bianco
- Branco Branco
- RED Red
- Rojo Rojo
- Rouge Rouge
- Vermelho Vermelho
- BLK Black
- Negro Negro
- Noir Noir
- Preto Preto