

INSTALLATION MANUAL

AIR CONDITIONER

Please read this installation manual completely before installing the product. Installation work must be performed in accordance with the national wiring standards by authorized personnel only. Please retain this installation manual for future reference after reading it thoroughly.

Multi Type



MFL68280103
Rev.04_122120

www.lghvac.com
www.lg.com

Copyright © 2015 - 2020 LG Electronics Inc. All Rights Reserved.

FLEX MULTI SPLIT INSTALLATION INSTRUCTIONS

IMPORTANT!

Please read this instruction sheet completely before installing the product.

This air conditioning system meets strict safety and operating standards. As the installer or service person, it is an important part of your job to install or service the system so it operates safely and efficiently.

WARNING

- Installation or repairs made by unqualified persons can result in hazards to you and others. Installation MUST comply with local building codes or, in the absence of local codes, with the National Electrical Code NFPA 70/ANSI C1-1993 or current edition and Canadian Electrical Code Part1 CSA C.22.1.
- The information contained in this manual is intended for use by a qualified service technician familiar with safety procedures and equipped with the proper tools and test instruments.
- Failure to carefully read and follow all instructions in this manual can result in equipment malfunction, property damage, personal injury and/or death.
- Do not turn on the breaker or power under condition that front panel, cabinet, top cover, control box cover are removed or opened. Otherwise, it may cause fire, electric shock, explosion or death.

CAUTION: Improper installation, adjustment, alteration, service or maintenance can void the warranty.

The weight of the condensing unit requires caution and proper handling procedures when lifting or moving to avoid personal injury. Use care to avoid contact with sharp or pointed edges.

Safety Precautions

- Always wear safety glasses and work gloves when installing equipment.
- Never assume electrical power is disconnected. Check with meter and equipment.
- Keep hands out of fan areas when power is connected to equipment.
- R410A causes frostbite burns.
- R410A is toxic when burned.

NOTE TO INSTALLING DEALER : The Owners Instructions and Warranty are to be given to the owner or prominently displayed near the indoor Air Handler Unit.

SPECIAL WARNINGS

When wiring:

Electrical shock can cause severe personal injury or death. Only a qualified, experienced electrician should attempt to wire this system.

- Do not supply power to the unit until all wiring and tubing are completed or reconnected and checked.
- Highly dangerous electrical voltages are used in this system. Carefully refer to the wiring diagram and these instructions when wiring. Improper connections and inadequate grounding can cause accidental injury or death.
- Ground the unit following local electrical codes.
- Connect all wiring tightly. Loose wiring may cause overheating at connection points and a possible fire hazard.

When transporting:

Be careful when picking up and moving the indoor and outdoor units. Get a partner to help, and bend your knees when lifting to reduce strain on your back. Sharp edges or thin aluminum fins on the air conditioner can cut your fingers.

When installing...

... in a wall: Make sure the wall is strong enough to hold the unit's weight.

It may be necessary to construct a strong wood or metal frame to provide added support.

... in a room: Properly insulate any tubing run inside a room to prevent "sweating" that can cause dripping and water damage to wall and floors.

... in moist or uneven locations: Use a raised concrete pad or concrete blocks provide a solid, level foundation for the outdoor unit. This prevents water damage and abnormal vibration.

... in an area with high winds: Securely anchor the outdoor unit down with bolts and a metal frame. Provide a suitable air baffle.

... in a snowy area(for Heat Pump Model): Install the outdoor unit on a raised platform that is higher than drifting snow. Provide snow vents.

When connecting refrigerant tubing

- Keep all tubing runs as short as possible.
- Use the flare method for connecting tubing.
- Check carefully for leaks before starting the test run.

When servicing











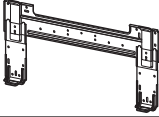
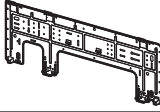
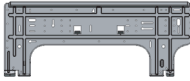
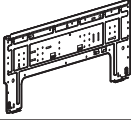



- Turn the power OFF at the main power box(mains) before opening the unit to check or repair electrical parts and wiring.
- Keep your fingers and clothing away from any moving parts.
- Clean up the site after you finish, remembering to check that no metal scraps or bits of wiring have been left inside the unit being serviced.

TABLE OF CONTENTS







4	INSTALLATION PARTS PROVIDED
5	SAFETY INSTRUCTIONS
8	INSTALLATION OF INDOOR, OUTDOOR UNIT
8	Select the best location
10	Seaside Applications and Installation
11	Seasonal Wind And Cautions In Winter
12	Piping length and elevation
14	INSTALLATION
14	Connecting the piping
18	How To Fix
19	Wiring Connection
19	Conduit connection
20	Ceiling dimension and hanging bolt location
21	How to Fix
21	Wiring Connection
21	Conduit connection
22	Installation of Wired Remote Controller(Optional)
24	Installation of Decorative Panel
26	Drain Piping
29	FLARING WORK AND CONNECTION OF PIPING
29	Flaring work
30	Connection of piping - Outdoor
33	Installation
34	Installation of The Main Unit
35	CONNECTING THE CABLE BETWEEN INDOOR UNIT, DISTRIBUTOR UNIT AND OUTDOOR UNIT
35	Connect the cable to the Indoor unit
36	Connect the cable to the Distributor unit
38	Connect the cable to the Outdoor unit
40	Connection method of the connecting cable(Example)
41	CHECKING THE DRAINAGE, INSULATING THE PIPE AND SPECIAL PIPING APPLICATIONS
41	Checking the drainage
41	Insulating the Pipe and Special Piping Applications
42	AIR PURGING AND EVACUATION
42	Leak Checking
43	Evacuation
44	CHARGING
46	INSTALLATION PI485
47	TEST RUNNING
48	FUNCTION
48	DIP S/W Setting
49	Forced Cooling Operation
50	Wiring Error Check
50	Saving Power Consumption
51	Night Quiet Mode
52	Mode Lock
53	PCB Display(18/24/60 k Model Only)
54	MAX COMBINATION CAPACITY

Installation Parts Provided









[Wall mounted / ART COOL Mirror]

Type 1	Type 2	Type 3		Type 4	
Installation plate	Installation plate	Installation plate		Installation plate	
					
Type "B" screw	Type "B" screw	Type "B" screw	Type "C" screw	Type "B" screw	Type "C" screw
					
Type "A" screw	Type "A" screw	Type "A" screw		Type "A" screw	
					
Remote control holder	Remote control holder	Remote control holder		Remote control holder	
					

[Ceiling Concealed Duct Type]

Name	Clamp metal	Insulation for fitting	Screws for duct flanges	Clamp	Conduit Bracket
Quantity	1 EA	1 set	1 set	8 EA	1 EA
Shape		 for gas pipe for liquid pipe			 Conduit Bracket  Screw(M4) 2 EA

[Ceiling Cassette Type]

Name	Drain hose	Clamp metal	Washer for hanging bracket	Clamp	Conduit Bracket	Insulation for fitting	Remote control holder
Quantity	1 EA	1 EA	8 EA	8 EA	1 EA	1 SET	1 EA
Shape					 Conduit Bracket  Screw(M4) 2 EA	 for gas pipe for liquid pipe	

Safety Instructions

The following safety guidelines are intended to prevent unforeseen risks or damage from unsafe or incorrect operation of the appliance.

The guidelines are separated into 'WARNING' and 'CAUTION' as described below.

-  This symbol is displayed to indicate matters and operations that can cause risk. Read the part with this symbol carefully and follow the instructions in order to avoid risk.

WARNING

This indicates that the failure to follow the instructions can cause serious injury or death.

CAUTION

This indicates that the failure to follow the instructions can cause the minor injury or damage to the product.

WARNING

Installation

- Always perform grounding.
 - Otherwise, it may cause electrical shock.
- Don't use a power cord, a plug or a loose socket which is damaged.
 - Otherwise, it may cause a fire or electrical shock.
- For installation of the product, always contact the service center or a professional installation agency.
 - Otherwise, it may cause a fire, electrical shock, explosion or injury.
- Securely attach the electrical part cover to the indoor unit and the service panel to the outdoor unit.
 - If the electrical part cover of the indoor unit and the service panel of the outdoor unit are not attached securely, it could result in a fire or electric shock due to dust, water, etc.
- Always install an air leakage breaker and a dedicated switching board.
 - No installation may cause a fire and electrical shock.
- Do not keep or use flammable gases or combustibles near the air conditioner.
 - Otherwise, it may cause a fire or the failure of product.
- Ensure that an installation frame of the outdoor unit is not damaged due to use for a long time.
 - It may cause injury or an accident.
- Do not disassemble or repair the product randomly.
 - It will cause a fire or electrical shock.
- Do not install the product at a place that there is concern of falling down.
 - Otherwise, it may result in personal injury.

* The figure can be changed according to model.

- Use caution when unpacking and installing.
 - Sharp edges may cause injury.
- Use a vacuum pump or Inert (nitrogen) gas when doing leakage test or air purge. Do not compress air or Oxygen and Do not use Flammable gases. Otherwise, it may cause fire or explosion.
 - There is the risk of death, injury, fire or explosion.

Operation

- Do not share the outlet with other appliances.
 - It will cause an electric shock or a fire due to heat generation.
- Do not use the damaged power cord.
 - Otherwise, it may cause a fire or electrical shock.
- Do not modify or extend the power cord randomly.
 - Otherwise, it may cause a fire or electrical shock.
- Take care so that the power cord may not be pulled during operation.
 - Otherwise, it may cause a fire or electrical shock.
- Unplug the unit if strange sounds, smell, or smoke comes from it.
 - Otherwise, it may cause electrical shock or a fire.
- Keep the flames away.
 - Otherwise, it may cause a fire.
- Take the power plug out if necessary, holding the head of the plug and do not touch it with wet hands.
 - Otherwise, it may cause a fire or electrical shock.
- Do not use the power cord near the heating tools.
 - Otherwise, it may cause a fire and electrical shock.
- Do not open the suction inlet of the indoor/outdoor unit during operation.
 - Otherwise, it may electrical shock and failure.
- Do not allow water to run into electrical parts.
 - Otherwise, it may cause the failure of machine or electrical shock.
- Hold the plug by the head when taking it out.
 - It may cause electric shock and damage.
- Never touch the metal parts of the unit when removing the filter.
 - They are sharp and may cause injury.
- Do not step on the indoor/outdoor unit and do not put anything on it.
 - It may cause an injury through dropping of the unit or falling down.
- Do not place a heavy object on the power cord.
 - Otherwise, it may cause a fire or electrical shock.
- When the product is submerged into water, always contact the service center.
 - Otherwise, it may cause a fire or electrical shock.
- Take care so that children may not step on the outdoor unit.
 - Otherwise, children may be seriously injured due to falling down.

 **CAUTION****Installation**

- Install the drain hose to ensure that drain can be securely done.
 - Otherwise, it may cause water leakage.
- Install the product so that the noise or hot wind from the outdoor unit may not cause any damage to the neighbors.
 - Otherwise, it may cause dispute with the neighbors.
- Always inspect gas leakage after the installation and repair of product.
 - Otherwise, it may cause the failure of product.
- Keep level parallel in installing the product.
 - Otherwise, it may cause vibration or water leakage.
- Do not install the unit in potentially explosive atmospheres.

Operation

- Avoid excessive cooling and perform ventilation sometimes.
 - Otherwise, it may do harm to your health.
- Use a soft cloth to clean. Do not use wax, thinner, or a strong detergent.
 - The appearance of the air conditioner may deteriorate, change color, or develop surface flaws.
- Do not use an appliance for special purposes such as preserving animals vegetables, precision machine, or art articles.
 - Otherwise, it may damage your properties.
- Do not place obstacles around the flow inlet or outlet.
 - Otherwise, it may cause the failure of appliance or an accident.

Installation of Indoor, Outdoor Unit

Read completely, then follow step by step.

Select the best location

Indoor unit

1. Do not have any heat or steam near the unit.
2. Select a place where there are no obstacles in front of the unit.
3. Make sure that condensation drainage can be conveniently routed away.
4. Do not install near a doorway.
5. Ensure the unit is unobstructed, allow proper space on all sides according to the arrows and distance measurements in the figures.
6. Use a Metal Detector or Metal Scanner to locate studs to prevent unnecessary damage to the wall.

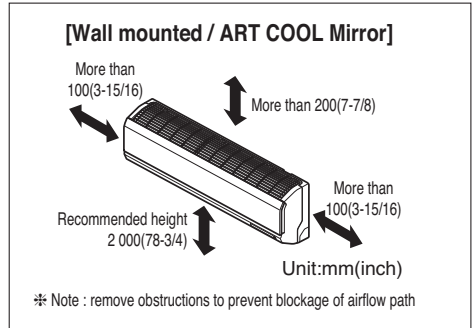

[Ceiling Concealed Duct Type]

Top view

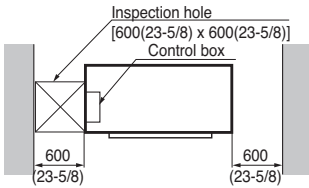

Front view

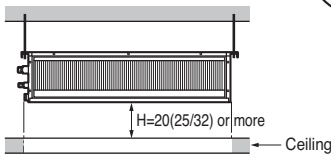

[Ceiling Cassette Type]

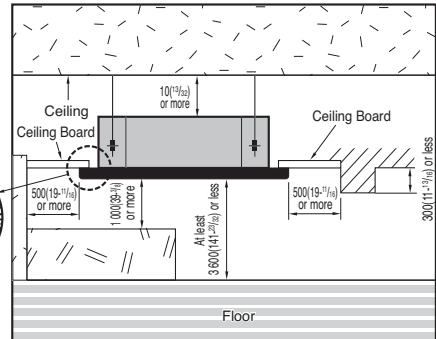

[Console]

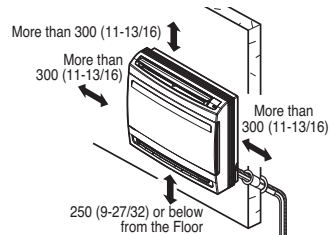

Unit: mm(inch)

[ART COOL Gallery]

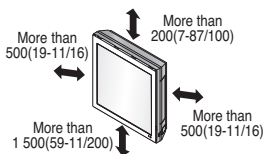

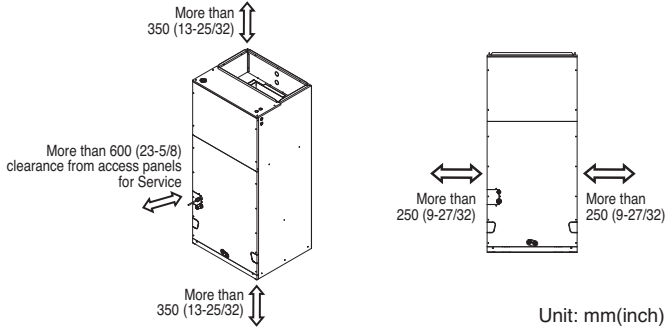
[Vertical Air Handling Unit]**Outdoor unit**

1. If an awning is built over the unit to prevent direct sunlight or rain exposure, make sure that heat radiation from the condenser is not restricted.
2. Ensure the unit is unobstructed, allow proper space on all sides according to the arrows and distance measurements in the figures.
3. Do not place animals and plants in the path of the warm air.
4. Take the air conditioner weight into account and select a place where noise and vibration are minimum.
5. Select a place so that the warm air and sound from the air conditioner does not disturb neighbors.
6. Place that can sufficiently endure the weight and vibration of the outdoor unit and where even installation is possible.
7. Place that has no direct influence of snow or rain.
8. Place with no danger of snowfall or icicle drop.
9. Place without weak floor or base such as decrepit part of the building or with a lot of snow accumulation.

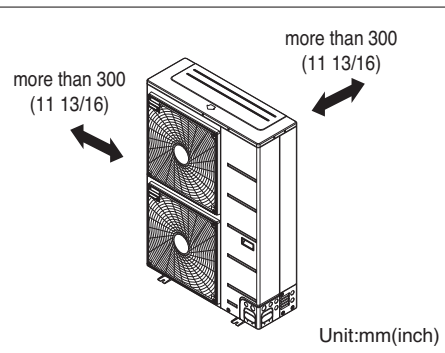
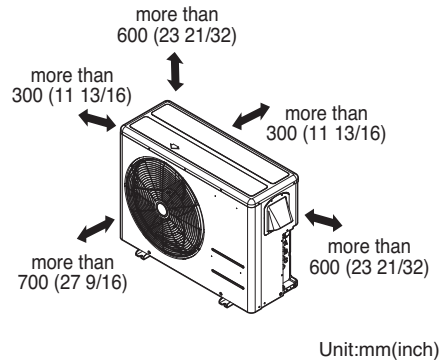
**Rooftop Installations:**

If the outdoor unit is installed on a roof structure, be sure to level the unit. Ensure the roof structure and anchoring method are adequate for the unit location. Consult local codes regarding rooftop mounting.

Seaside Applications and Installation

⚠ CAUTION

1. Air conditioners should not be installed in areas where corrosive gases, such as acid or alkaline gas, are produced.
2. Do not install the product where it could be exposed to sea wind (salty wind) directly. It can result corrosion on the product. Corrosion, particularly on the condenser and evaporator fins, could cause product malfunction or inefficient performance.
3. If outdoor unit is installed close to the seaside, it should avoid direct exposure to the sea wind.

1. Selecting the location(Outdoor Unit)

- 1) If the outdoor unit is to be installed close to the seaside, direct exposure to the sea wind should be avoided. Install the outdoor unit on the opposite side of the sea wind direction.

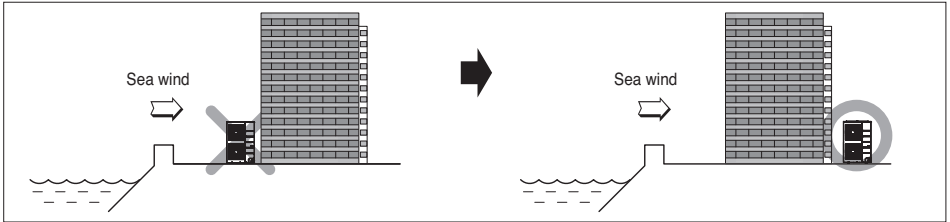

- 2) In case, to install the outdoor unit on the seaside, set up a windbreaker/barrier, to lessen the unit's exposure to sea air

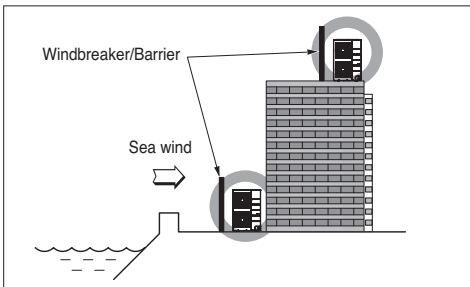

- It should be strong enough (like concrete) to obstruct the wind from the sea.
- The height and width should be more than 150 % of the outdoor unit.
- A minimum of 70 cm (27 1/16 inches) of space between outdoor unit and the windbreak for easy air flow.

- 3) Select a well-drained place.

Periodic (more than once/year) cleaning of the dust or salt particles stuck on the heat exchanger using water is recommended.

Seasonal Wind And Cautions In Winter

- Sufficient measures are required in a snow area or severe cold area in winter so that product can be operated well.
- Get ready for seasonal wind or snow in winter even in other areas.
- Install a suction and discharge duct not to let in snow or rain.
- Install the outdoor unit not to come in contact with snow directly. If snow piles up and freezes on the air suction hole, the system may malfunction. If it is installed at snowy area, attach the hood to the system.
- Install the outdoor unit at the higher installation console by 50 cm than the average snowfall (annual average snowfall) if it is installed at the area with much snowfall.
- Where snow accumulated on the upper part of the Outdoor Unit by more than 10 cm, always remove snow for operation.

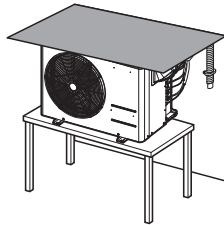

1. The height of H frame must be more than 2 times the snowfall and its width shall not exceed the width of the product. (If width of the frame is wider than that of the product, snow may accumulate)
2. Don't install the suction hole and discharge hole of the Outdoor Unit facing the seasonal wind.

Piping length and elevation

Multi Piping Type

Unit : m(ft)

Outdoor Unit Capacity (kBTu/h class)	Max total length of all pipes (A+B)/(A+B+C)/(A+B+C+D)	Max length of each pipe (A/B/C/D)	Min length of each pipe (A/B/C/D)	Max Elevation between each indoor unit and outdoor unit (h1)	Max elevation between indoor units (h2)	Max.Combination of Indoor unit (kBTu/h class)
18	50(164)	25(82)	3(10)	15(49)	7.5(25)	24
24	70(230)	25(82)	3(10)	15(49)	7.5(25)	33
30	75(246)	25(82)	3(10)	15(49)	7.5(25)	40
36	75(246)	25(82)	3(10)	15(49)	7.5(25)	48

Calculation method for total capacity index = sum up the capacity index of connected indoor units.

* Total capacity index = [Sum of all VAHU & Ceiling Concealed Duct (High Static) type indoor units capacity (if any)] x 1.3 + Sum of all other indoor unit's capacity

* The multiplier(1.3) is only necessary for calculation of combination ratio.

* For combinations where it contains one of below conditions, multiplier is 1.2 instead of 1.3. (See example 3)

- 1) ONE 24 k high static ducted unit/VAHU AND ONE 24 k high static ducted unit/VAHU
- 2) ONE 24 k high static ducted unit/VAHU AND ONE 36 k high static ducted unit/VAHU

Indoor unit Capacity (kBTu/h class)	Pipe Diameter Unit : mm(inch)	
	Gas	Liquid
7, 9, 12, 15	9.52(3/8)	6.35(1/4)
15(Console), 18, 24	12.7(1/2)	6.35(1/4)
36	15.88(5/8)	9.52(3/8)

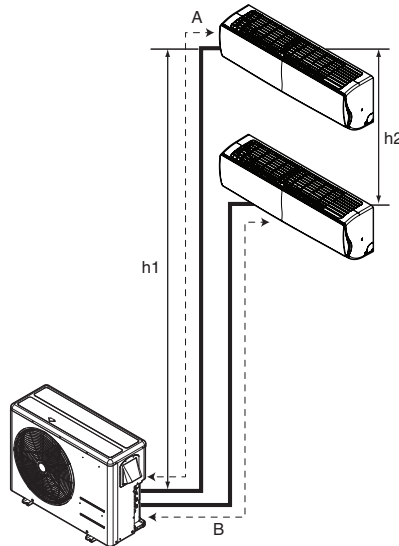

CAUTION

Multiple Piping Type

Capacity is based on standard length and maximum allowance length is on the basis of reliability.

Distributor Piping Type

Unit : m(ft)

Outdoor Unit Capacity (kBtu/h class)	Max total length of all pipes (Main + Branch pipes)	Max length of Main pipe (A+B+C)	Max length of Branch pipes	Max length of each Branch pipe	Min length of each pipe (Main / Branch pipes)	Max Elevation Between each indoor unit and outdoor unit (h1)	Max Elevation Between indoor (h2)	Max Combination of indoor unit (kBtu/h class)
48	145(476)	55(180)	90(295)	15(49)	3(10)	30(98)	15(49)	65
54	145(476)	55(180)	90(295)	15(49)	3(10)	30(98)	15(49)	73
60	145(476)	55(180)	90(295)	15(49)	3(10)	30(98)	15(49)	83

Calculation method for total capacity index = sum up the capacity index of connected indoor units.

* Total capacity index = [Sum of all VAHU & Ceiling Concealed Duct (High Static) type indoor units capacity (if any)] x 1.3 + Sum of all other indoor unit's capacity

* The multiplier(1.3) is only necessary for calculation of combination ratio.

* For combinations where it contains one of below conditions, multiplier is 1.2 instead of 1.3. (See example 3)

- 1) ONE 24 k high static ducted unit/VAHU AND ONE 24 k high static ducted unit/VAHU
- 2) ONE 24 k high static ducted unit/VAHU AND ONE 36 k high static ducted unit/VAHU

Indoor unit Capacity (kBtu/h class)	Pipe Diameter Unit : mm(inch)	
	Gas	Liquid
7, 9, 12, 15	9.52(3/8)	6.35(1/4)
15(Console), 18, 24	12.7(1/2)	6.35(1/4)
36	15.88(5/8)	9.52(3/8)

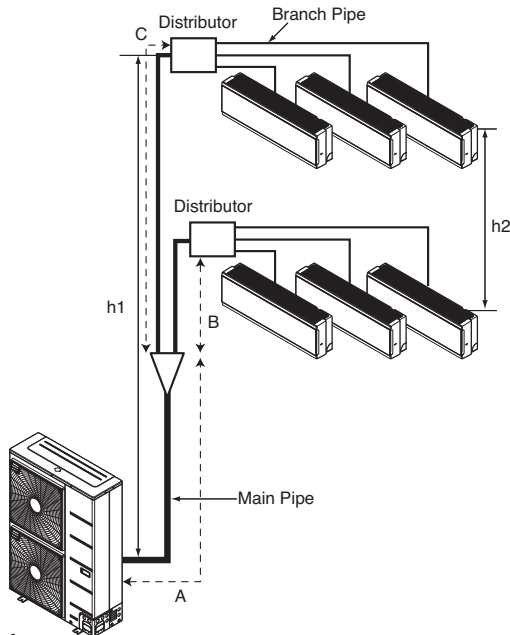

CAUTION

Capacity is based on standard length and maximum allowance length is on the basis of reliability.

Installation

[Wall mounted / ART COOL Mirror]

Connecting the piping

Standard / Artcool Mirror Type

1. Prepare the indoor unit's piping and drain hose for installation through the wall.
2. Remove the plastic tubing retainer(see the illustration on the right) and pull the tubing and drain hose away from chassis.
3. Route the indoor tubing and the drain hose to the required piping hole position.
4. Insert the piping, drain hose, and the connecting cable into the piping hole.
5. Insert the connecting cable into the indoor unit.
 - Don't connect the cable to the indoor unit.
 - Make a small loop with the cable for easy connection later.
6. Tape the tubing and drain hose.

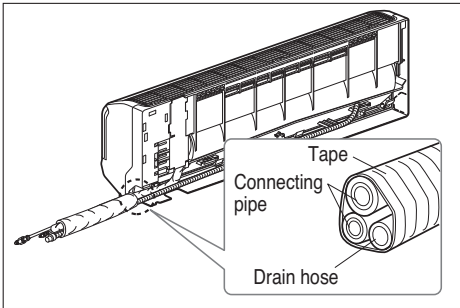
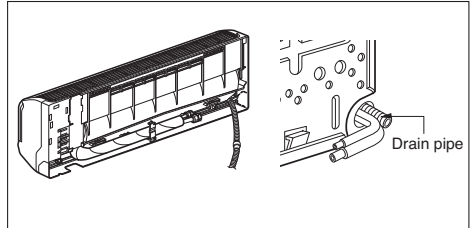
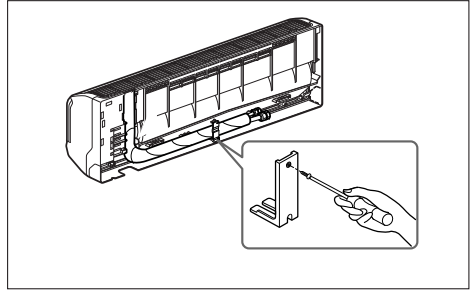

For right rear piping

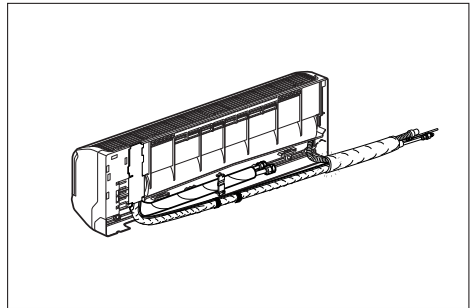

For left rear piping

7. Indoor unit installation

- Hang the indoor unit from the hooks at the top of the installation plate.
- Insert the spacer etc. between the indoor unit and the installation plate and separate the bottom of the indoor unit from the wall.

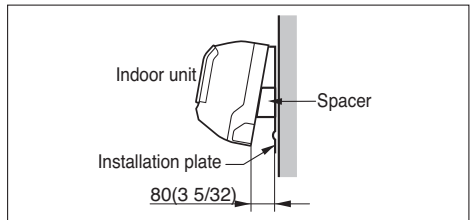

Standard Libero / Artcool Libero Type

1. Pull the screw cap at the bottom of the indoor unit
2. Remove the chassis cover from the unit by loosening screws

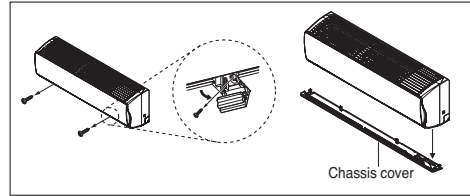

3. Pull back the tubing holder.
4. Remove pipe port cover and positioning the tubing

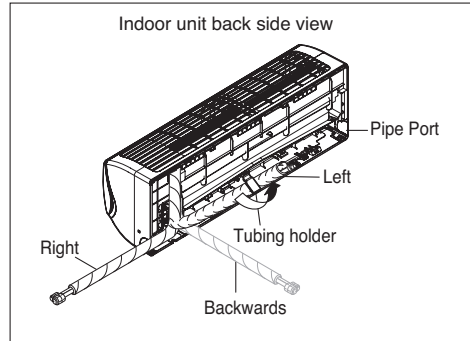

5. Indoor unit installation

- 1) Hook the indoor unit onto the upper portion of the installation plate. (engage the three hooks at the top of the indoor unit with the upper edge of the installation plate) Ensure that the hooks are properly seated on the installation plate by moving it left and right
- 2) Unlock the tubing holder from the chassis and mount between the chassis and installation plate in order to separate the bottom side of the indoor unit from the wall

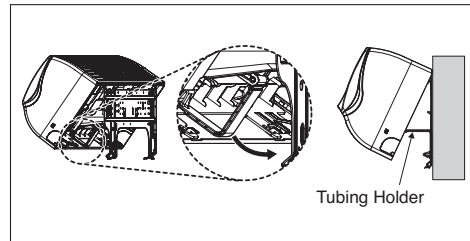
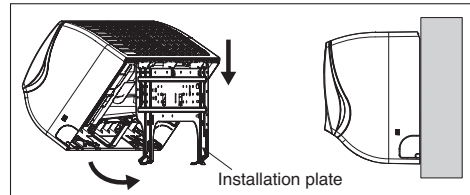

Connecting the piping to the indoor unit and drain hose to drain pipe.

1. Align the center of the pipes and sufficiently tighten the flare nut by hand.
2. Tighten the flare nut with a wrench.

Outside diameter		Torque		
mm	inch	N·m	kgf·m	lbf·ft
Ø 6.35	1/4	14~18	1.4~1.8	10~13
Ø 9.52	3/8	34~42	3.5~4.3	25~31
Ø 12.7	1/2	49~61	5.0~6.2	36~45
Ø 15.88	5/8	69~82	7.0~8.4	51~60
Ø 19.05	3/4	100~120	10.0~12.2	73~88

3. Next, extend the indoor unit's drain hose. Then attach the drain pipe.

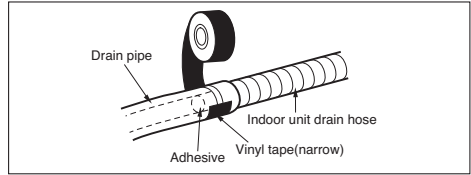
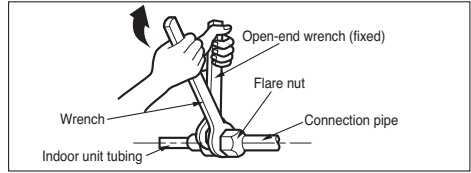
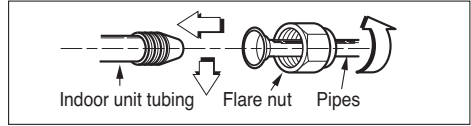

⚠ CAUTION

Installation Information. For left piping. Follow the instruction below.

Good case

- Press on the upper side of clamp and unfold the tubing to slowly downward.

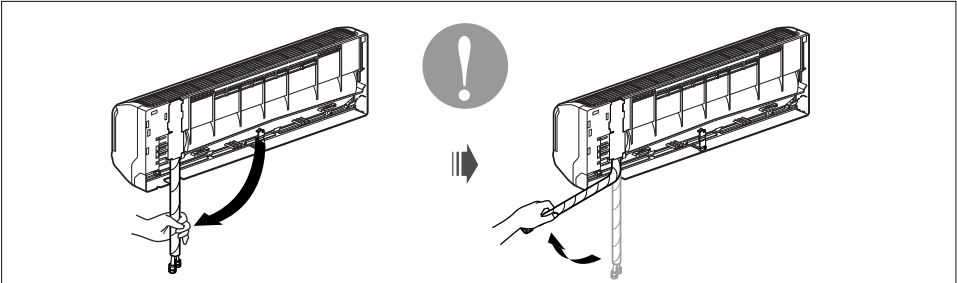

Bad case

- Bending the pipe from right to left may cause damage to the tubing.

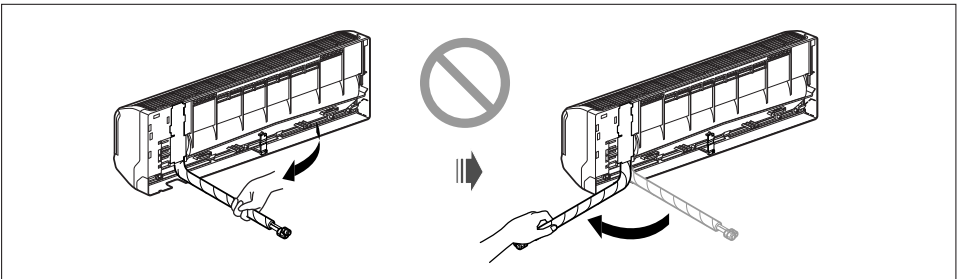

Wrap the insulation material around the connecting portion.

1. Overlap the connection pipe insulation and the indoor unit pipe heat insulation material. Bind them together with vinyl tape so that there is no gap.
2. Wrap the area which accommodates the rear piping housing section with vinyl tape.

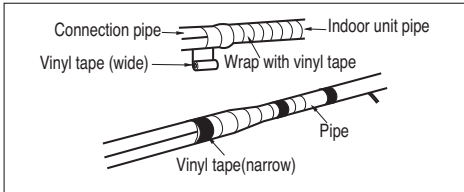
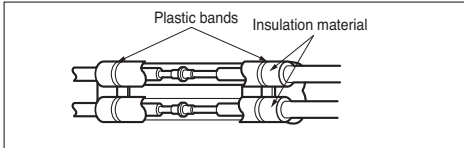

3. Bundle the piping and drain hose together by wrapping them with vinyl tape over the range within which they fit into the rear piping housing section.

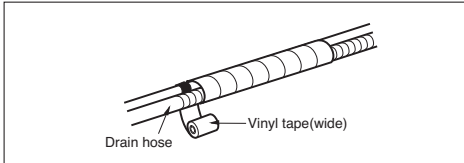

Reroute the pipings and the drain hose across the back of the chassis.

Finishing the indoor unit installation

Standard / Artcool Mirror Type

1. Remove the spacer.
2. Ensure that the hooks are properly seated on the installation plate by moving it left and right.
3. Press the lower left and right sides of the unit against the installation plate until the hooks engage into their slots (clicking sound).

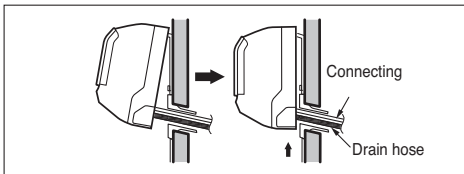
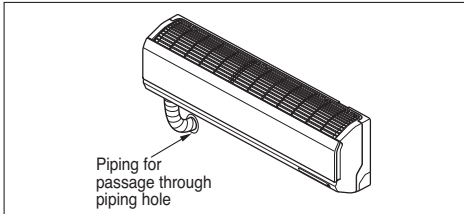

Standard Libero / Artcool Libero Type

1. Mount the tubing holder in the original position.
2. Ensure that the hooks are properly seated on the installation plate by moving it left and right.
3. Press the lower left and right sides of the unit against the installation plate until the hooks engage into their slots (clicking sound).
4. Finish the assembly by screwing the unit to the installation plate by using two pieces of type "C" screws. And assemble a chassis cover.

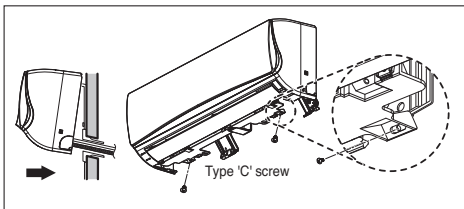

⚠ CAUTION

If the split type Indoor unit is installed in a wall having hole or opening near by or back side of the unit, then the air from other side of the wall can come inside the condition space through that hole / opening. That air can cause unwanted dew / water droplet formation when it comes in contact with body of the indoor unit. So all hole or opening on the wall must be blocked very well to avoid water dropping from the body of the unit.

Installation of filters

- 1) Detach two attached tapes from the plasma filter.

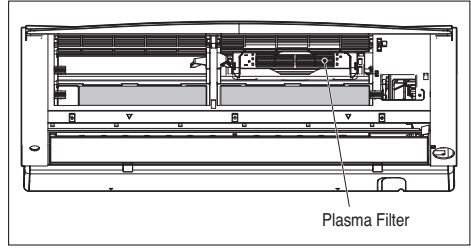

How To Fix

The wall you select should be strong and solid enough to prevent vibration

1. Mount the installation plate on the wall with type "A" screws. If mounting the unit on a concrete wall, use anchor bolts.
 - Mount the installation plate horizontally by aligning the centerline using a level.
2. Measure the wall and mark the centerline. It is also important to use caution concerning the location of the installation plate—routing of the wiring to power outlets is through the walls typically. Drilling the hole through the wall for piping connections must be done safely.

Indoor Type	Capacity (kBtu/h)	Type
Wall mounted / ART COOL Mirror	7/9/12/15	Type 1 / Type 3
	18/24	Type 2 / Type 4

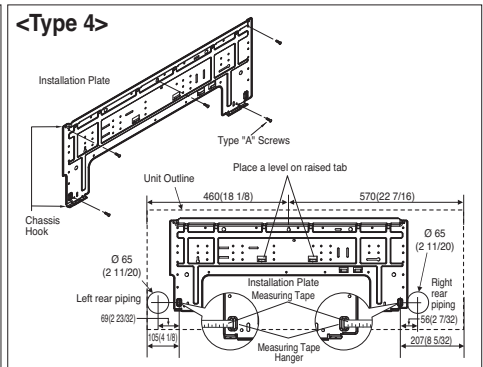
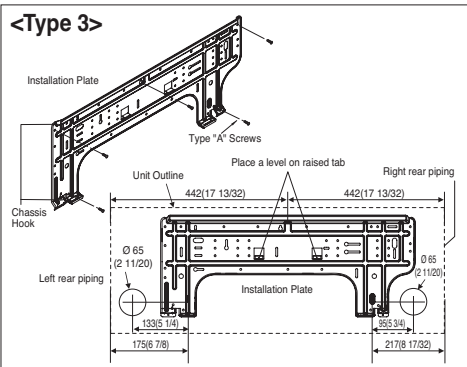
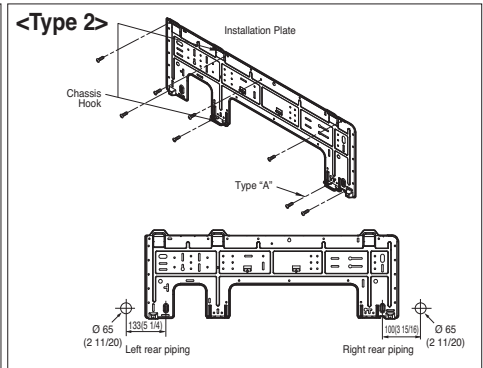
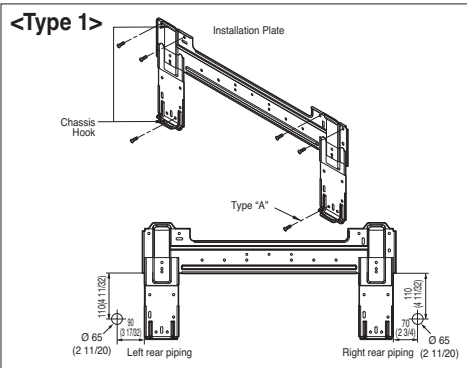

Wiring Connection

1. Connect the wires to the terminals on the control board individually according to the outdoor unit connection.
 - Ensure that the color of the wires of outdoor unit and the terminal No. are the same as those of indoor unit respectively.

Terminal Block in Indoor				
1(L1)	2(L2)	⊖	3	4

↑
Connected to Outdoor Unit

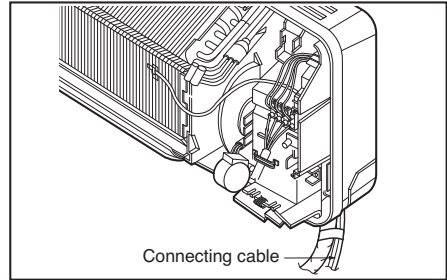

2. Attach the Grille onto the cabinet.
 - Grasp the lower left and right side of the Grille and engage four tabs on the top inside edge of the chassis.
 - Press the Grille toward the chassis until it goes back into place.

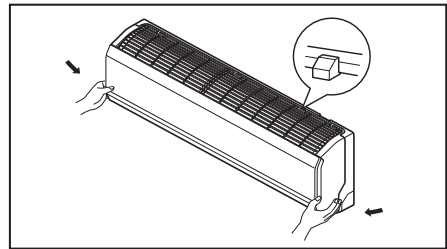

Conduit connection

1. Set the connecting cable into the terminal block of indoor unit, and tighten set screw to lock the conduit bracket to the indoor unit.
2. Join the conduit and the conduit bracket together.

CAUTION

Must use the elbow type (L-Type) conduit.

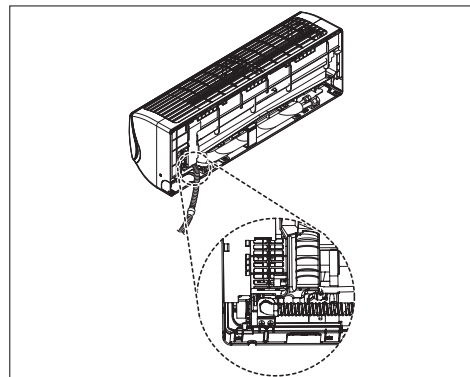
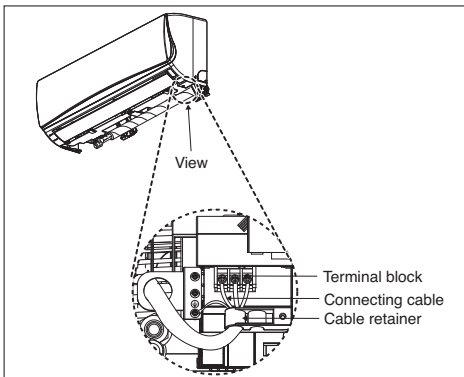
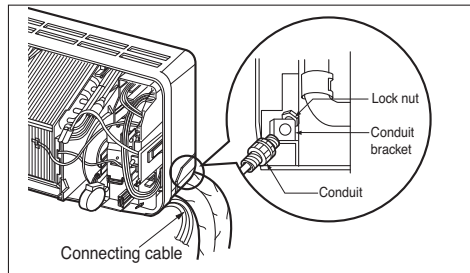
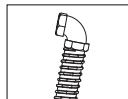

[Ceiling Cassette Type]

Ceiling dimension and hanging bolt location

- The dimensions of the paper model for installation are the same as those of the ceiling opening dimensions.

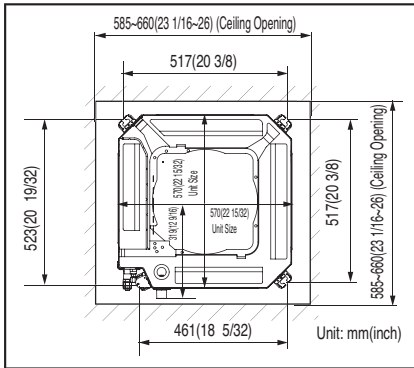
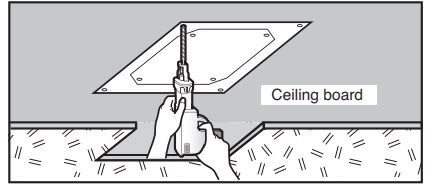
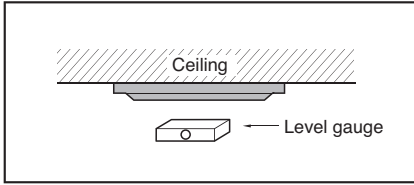

- Select and mark the position for fixing bolts and piping hole.
- Decide the position for fixing bolts slightly tilted to the drain direction after considering the direction of drain hose.
- Drill the hole for anchor bolt on the wall.

CAUTION

- This air-conditioner uses a drain pump.
- Install the unit horizontally using a level gauge.
- During the installation, care should be taken not to damage electric wires.

NOTICE

- Avoid the following installation location.
 - Such places as restaurants and kitchen where considerable amount of oil steam and flour is generated. These may cause heat exchange efficiency reduction, or water drops, drain pump mal-function. In these cases, take the following actions;
 - Make sure that ventilation fan is enough to cover all noxious gases from this place.
 - Ensure enough distance from the cooking room to install the air conditioner in such a place where it may not suck oily steam.
 - Avoid installing air conditioner in such places where cooking oil or iron powder is generated.
 - Avoid places where inflammable gas is generated.
 - Avoid place where noxious gas is generated.
 - Avoid places near high frequency generators.

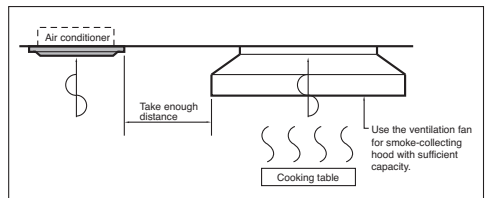

How to Fix

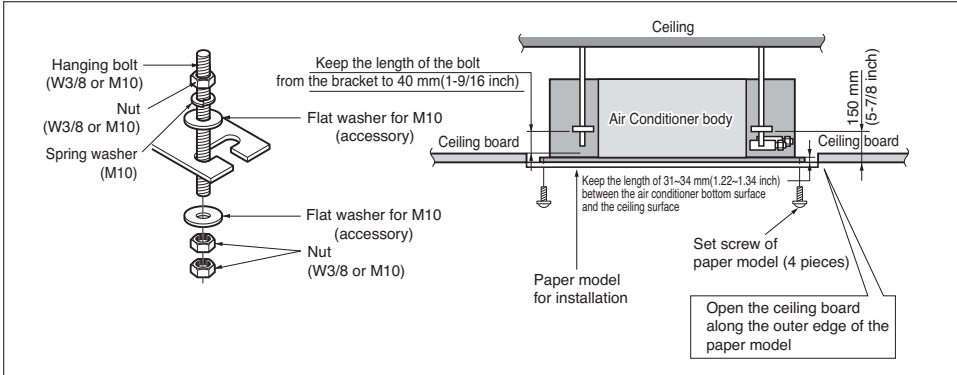

• The following parts are local purchasing.

- ① Hanging Bolt - W 3/8 or M10
- ② Nut - W 3/8 or M10
- ③ Spring Washer - M10
- ④ Plate Washer - M10

⚠ CAUTION

Tighten the nut and bolt to prevent unit from falling off.

Wiring Connection

• Open the control box cover and connect the remote control cord and indoor power wires.

TQ/TR series

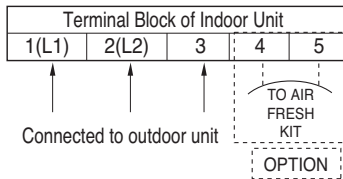

Conduit connection

- Remove the busing rubber product attached on the indoor unit.
- Join the conduit and the conduit bracket together using nut.
- Set the connecting cable into the terminal block of indoor unit, and tighten set screw to lock the conduit bracket to the indoor unit.

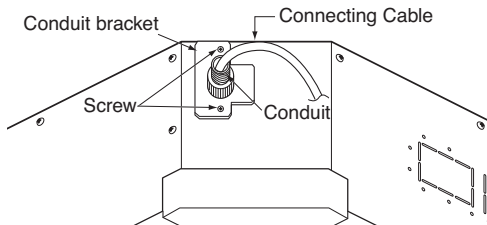

Installation of Wired Remote Controller(Optional)

1. Please fix tightly using provided screw after placing remote controller setup board on the place where you like to setup.

- Please set it up not to bend because poor setup could take place if setup board bends.
Please set up remote controller board fit to the reclamation box if there is a reclamation box.
- Install the product so as not to make a gap with the wall side and to prevent shaking after the installation.

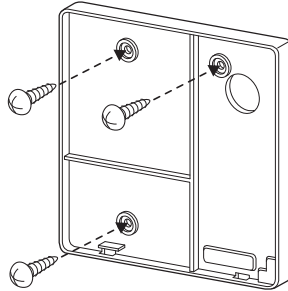

2. Can set up Wired remote controller cable into three directions.

- Setup direction: the surface of wall reclamation, upper, right
- If setting up remote controller cable into upper and right side, please set up after removing remote controller cable guide groove.

※ Remove guide groove with long nose.

- ① Reclamation to the surface of the wall
- ② Upper part guide groove
- ③ Right part guide groove

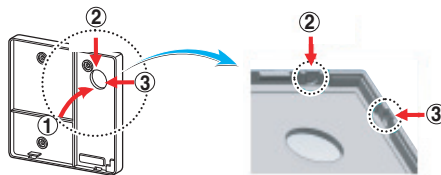

<Wire guide grooves>

3. Please fix remote controller upper part into the setup board attached to the surface of the wall, as the picture on the right, and then, connect with setup board by pressing lower part.

- Please connect not to make a gap at the remote controller and setup board's upper and lower, right and left part.
- Before assembly with the installation board, arrange the Cable not to interfere with circuit parts.

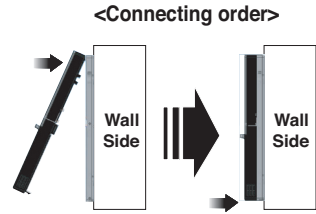

When separating remote controller from setup board, after inserting into the lower separating hole using screw driver and then, spinning clockwise, remote controller is separated.

- There are two separating holes. Please individually separate one at a time.
- Please be careful not to damage the inside components when separating.

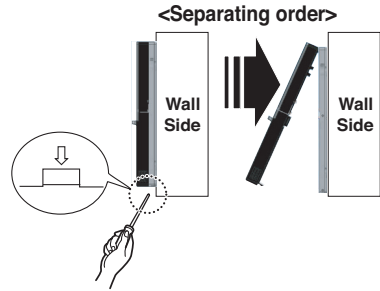

4. Please connect indoor unit and remote controller using connection cable.

12 V	Red
Signal	Yellow
GND	Black

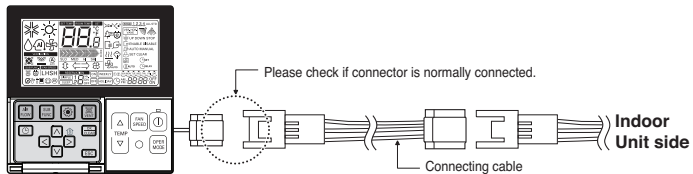

5. Please use extension cable if the distance between wired remote controller and indoor unit is more than 10 m(32.8 ft).

⚠ CAUTION

When installing the wired remote controller, do not bury it in the wall.

(It can cause damage in the temperature sensor.)

Do not install the cable to be 50 m(164 ft) or above.

(It can cause communication error.)

- When installing the extension cable, check the connecting direction of the connector of the remote controller side and the product side for correct installation.
- If you install the extension cable in the opposite direction, the connector will not be connected.
- Specification of extension cable: 2547 1007 22# 2 core 3 shield 5 or above.

Installation of Decorative Panel

**The decorative panel has its installation direction.
Before installing the decorative panel, always remove the paper template.**

1. Remove the packing and take out air inlet grille from front panel.

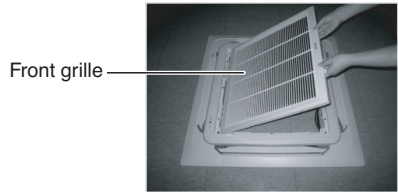

2. Remove the Corner covers of the panel.

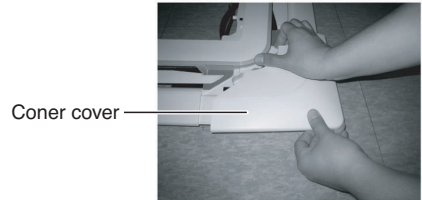

3. Fit the panel on the unit by inserting hooks as shown in picture.

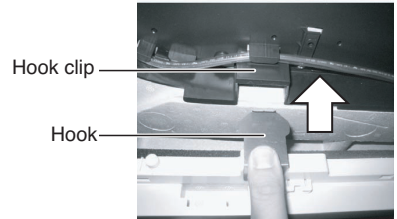

4. Insert two screws on diagonal corners of panel. Do not tighten the bolts completely. (The fixing screws are included in the indoor unit box.)

Check the alignment of panel with the ceiling. Height can be adjusted using hanging bolts as shown in picture. Insert the other two screws and tighten all screws completely.

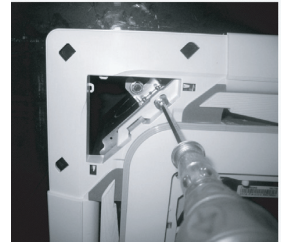

5. Fit the corner covers.

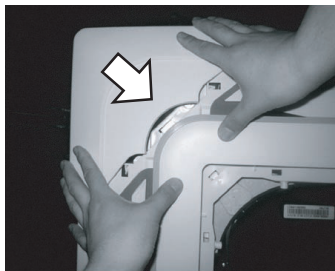

6. Open two screws of control panel cover.

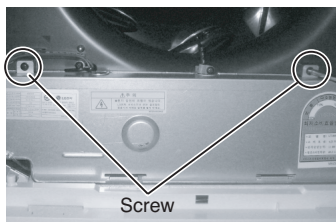

7. Connect one display connector and two vane control connectors of front panel to indoor unit PCB.

The position marking on PCB is as:

Display connector : CN-DISPLAY

Vane control connector: CN-VANE 1,2

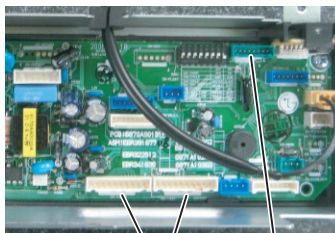

CN-VANE 1,2 CN-DISPLAY

8. Close the cover for control box.

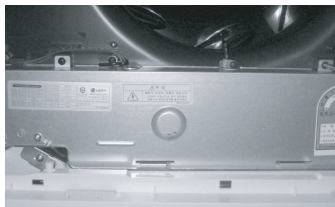

9. Install the air inlet grille and Filter on the panel.

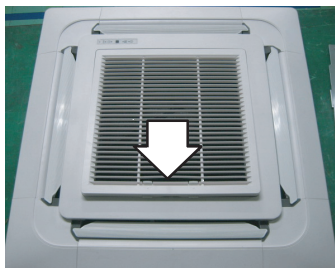

⚠ CAUTION

Install certainly the decorative panel. Cool air leakage causes sweating. ⇨ Water drops fall.

Good example

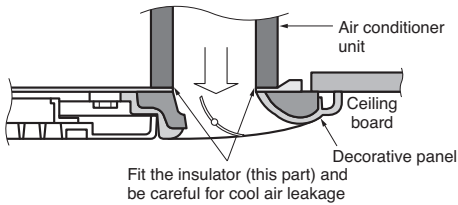

Bad example

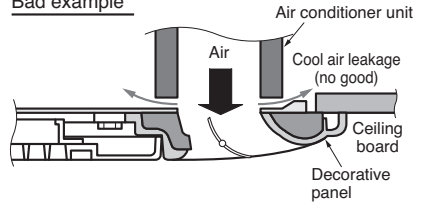

HEAT INSULATION

1. Use the heat insulation material for the refrigerant piping which has an excellent heat-resistance [over 120 °C(248 °F)].

2. Precautions in high humidity circumstance:

This air conditioner has been tested according to the "KS Standard Conditions with Mist" and confirmed that there is not any default. However, if it is operated for a long time in high humid atmosphere [dew point temperature: more than 23 °C(73.4 °F)], water drops are liable to fall. In this case, add heat insulation material according to the following procedure:

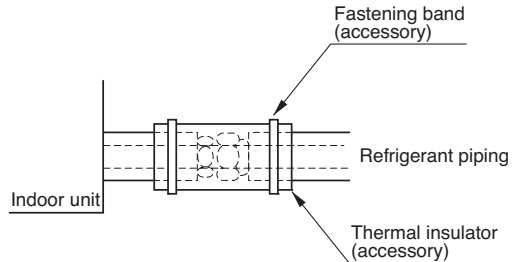

- Heat insulation material to be prepared... Adiabatic glass wool with thickness 10 to 20 mm.
- Stick glass wool on all air conditioners that are located in ceiling atmosphere.

Drain Piping

[Standard / Standard Libero / Artcool Mirror Type]

1. The drain hose should point downward for optimum drainage.

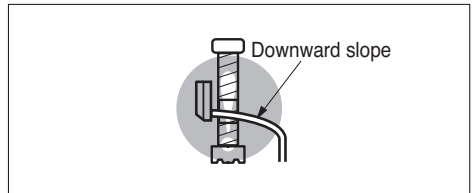

2. Incorrect Installation Examples:

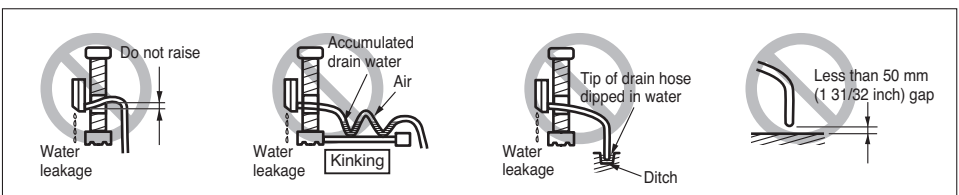

[Ceiling Concealed Duct/Ceiling Cassette Type]

- Drain piping must have down-slope (1/50 to 1/100): be sure not to provide up-and-down slope to prevent reversal flow.
- During drain piping connection, be careful not to exert extra force on the drain port on the indoor unit.
- The outside diameter of the drain connection on the indoor unit is 32 mm(1 1/4 inch).

Piping material: Polyvinyl chloride pipe inner diameter \varnothing 25 mm(1 inch) and pipe fittings

- Be sure to install heat insulation on the drain piping.

Heat insulation material: Polyethylene foam with thickness more than 8 mm(5/16 inch).

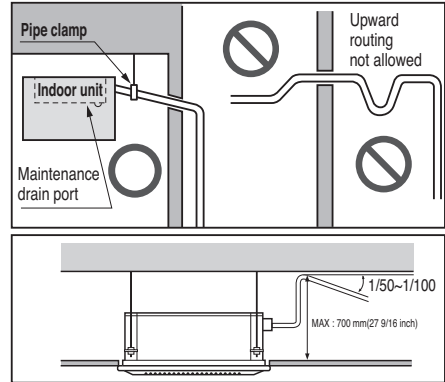

Drain test

The air conditioner uses a drain pump to drain water. Use the following procedure to test the drain pump operation:

- Connect the main drain pipe to the exterior and leave it provisionally until the test comes to an end.
- Feed water to the flexible drain hose and check the piping for leakage.
- Be sure to check the drain pump for normal operating and noise when electrical wiring is complete.
- When the test is complete, connect the flexible drain hose to the drain port on the indoor unit.

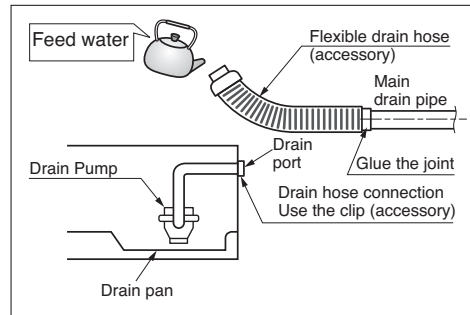

⚠ CAUTION

The supplied flexible drain hose should not be curved, neither screwed. The curved or screwed hose may cause a leakage of water.

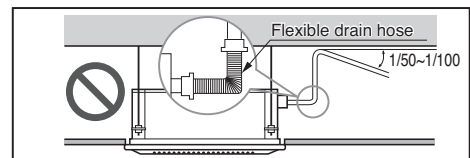

* The figure can be changed according to model.

Attention

1. Possible drain-head height is up to 700 mm (27 9/16 inch). So, it must be installed below 700 mm(27 9/16 inch).
2. Keep the drain hose downward up to 1/50~1/100 inclination.
Prevent any upward flow or reverse flow in any part.

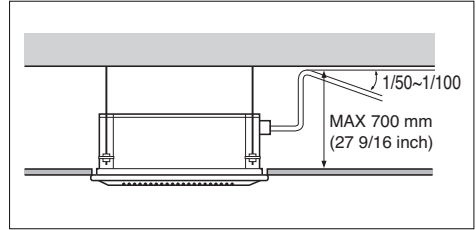

3. 5 mm(3/16 inch) or thicker formed thermal insulator is provided for the drain pipe.

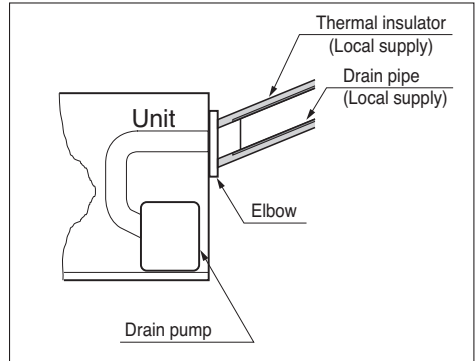

4. Upward routing is not allowed.
5. Be sure to check the drain pump for normal operation and abnormal noise when electrical wiring is complete.

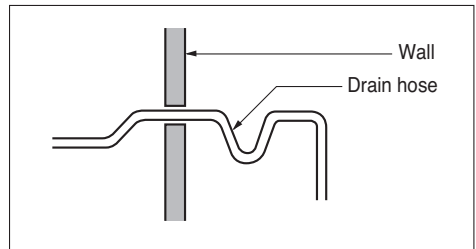

Flaring Work and Connection of Piping

Flaring work

Main cause of gas leakage is defect in flaring work. Carry out correct flaring work in the following procedure.

1) Cut the pipes and the cable.

- Use the accessory piping kit or the pipes purchased locally.
- Measure the distance between the indoor and the outdoor unit.
- Cut the pipes a little longer than measured distance.
- Cut the cable 1.5 m (4.9 ft) longer than the pipe length.

2) Burrs removal

- Completely remove all burrs from the cut cross section of pipe/tube.
- Put the end of the copper tube/pipe to downward direction as you remove burrs in order to avoid to let burrs drop in the tubing.

3) Putting nut on

- Remove flare nuts attached to indoor and outdoor units, than put them on pipe/tube having completed burr removal. (Not possible to put them on after flaring work)

4) Flaring work

- Carry out flaring work using flaring tool as shown below.

Pipe diameter Inch (mm)	A inch (mm)	
	Wing nut type	Clutch type
Ø 1/4 (Ø 6.35)	0.04~0.05 (1.1~1.3)	0~0.02 (0~0.5)
Ø 3/8 (Ø 9.52)	0.06~0.07 (1.5~1.7)	
Ø 1/2 (Ø 12.7)	0.06~0.07 (1.6~1.8)	
Ø 5/8 (Ø 15.88)	0.06~0.07 (1.6~1.8)	
Ø 3/4 (Ø 19.05)	0.07~0.08 (1.9~2.1)	

Firmly hold copper tube in a bar(or die) as indicated dimension in the table above.

5) Check

- Compare the flared work with figure.
- If flare is noted to be defective, cut off the flared section and do flaring work again.

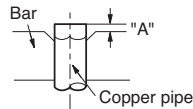
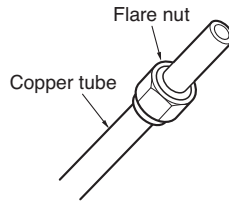
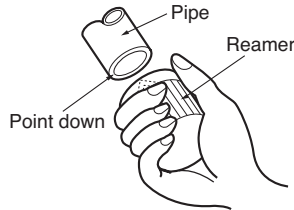
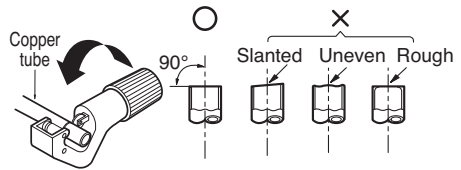

<Wing nut type>

<Clutch type>

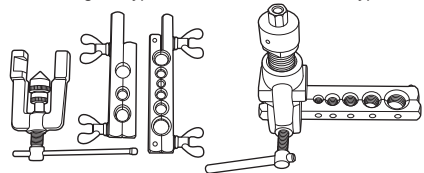

Smooth all round

Inside is shining without scratches.

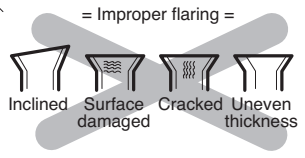
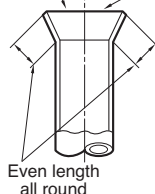

Connection of piping - Outdoor

Align the center of the piping and sufficiently tighten the flare nut by hand.

Connecting pipe order

- 1) ROOM A~C gas side pipe
- 2) ROOM A~C liquid side pipe

Finally, tighten the flare nut with torque wrench until the wrench clicks.

- When tightening the flare nut with torque wrench ensure the direction for tightening follows the arrow on the wrench.

Outside diameter		Torque		
mm	inch	N·m	kgf·m	lbf·ft
Ø 6.35	1/4	14~18	1.4~1.8	10~13
Ø 9.52	3/8	34~42	3.5~4.3	25~31
Ø 12.7	1/2	49~61	5.0~6.2	36~45
Ø 15.88	5/8	69~82	7.0~8.4	51~60
Ø 19.05	3/4	100~120	10.0~12.2	73~88

BD Unit	Refrigerant Connections Pipe Size (inch (mm))		Connectable Indoor Unit Capacity (kBtu/h class)
	Liquid	Gas	
PMBD3620	1/4 (Ø 6.35) x 2 EA	3/8 (Ø 9.52) x 2 EA	7,9,12,15,18,24 k
PMBD3630	1/4 (Ø 6.35) x 3 EA	3/8 (Ø 9.52) x 3 EA	7,9,12,15,18,24 k
PMBD3640	1/4 (Ø 6.35) x 4 EA	3/8 (Ø 9.52) x 4 EA	7,9,12,15,18,24 k
PMBD3641	1/4 (Ø 6.35) x 4 EA	3/8 (Ø 9.52) x 3 EA	7,9,12,15,18,24 k (A,B,C ROOM)
		1/2 (Ø 12.7) x 1 EA	24,36 k (D ROOM)

※ BD Unit(PMBD3641) includes the socket.
 (Ø 12.7 → Ø 15.88 x 1 EA, Ø 6.35 → Ø 9.52 x 1 EA)

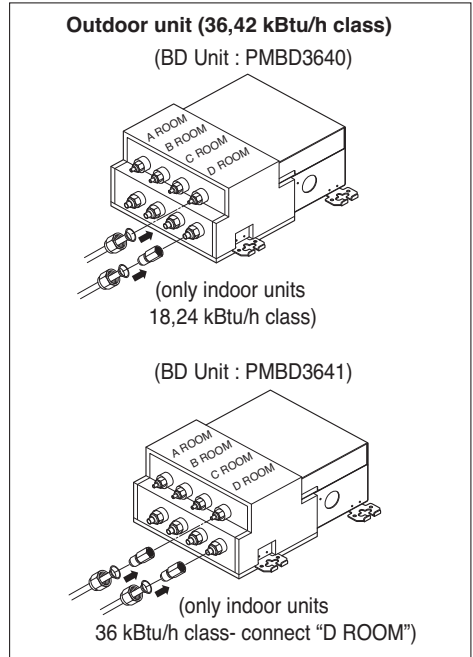
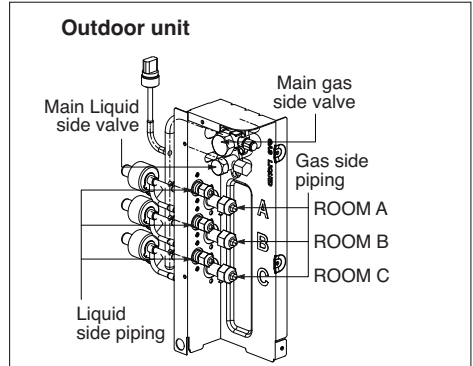
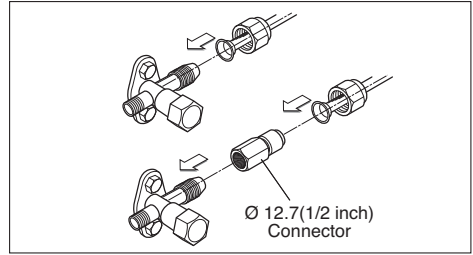

- For the units with capacity more than 48 kBTU/h, the installation piping is connectable in four directions.(refer to figure 1)
- When connecting in a downward direction, knock out the knockout hole of the base pan. (refer to figure 2)

Preventing foreign objects from entering (Figure3)

- Plug the pipe through-holes with putty or insulation material(procured locally)to stop up all gaps,as shown in the figure 3.
- Insects or small animals entering the outdoor unit may cause a short circuit in the electrical box.

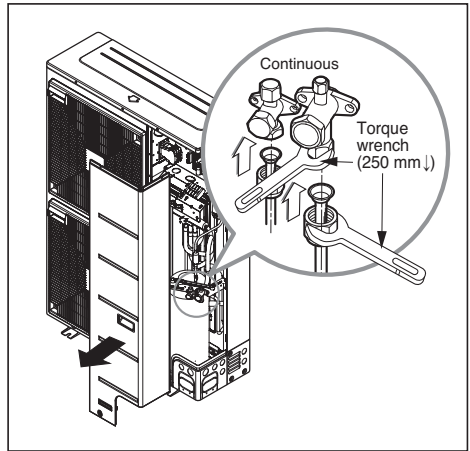

※ When tighten the pipe, hold the hexagonal body.

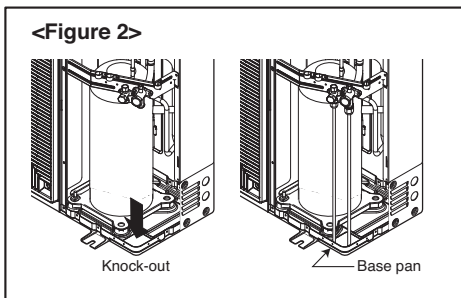
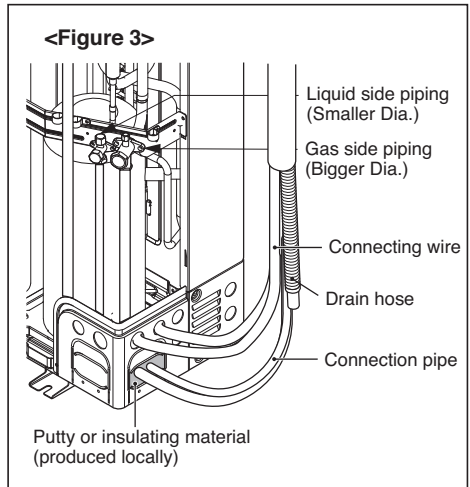
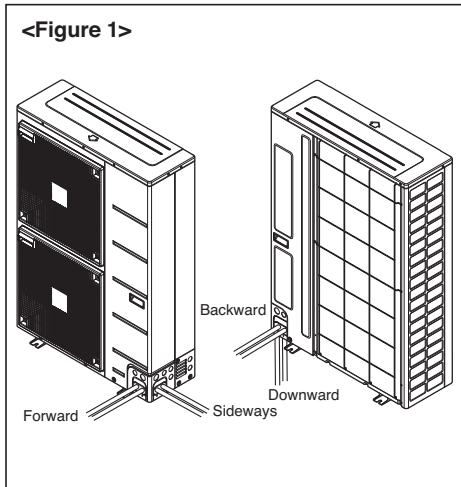

Branch

* For detailed dimensions, refer to the printed materials enclosed at the time of purchase the branch pipe.

[unit: mm]

Model	Gas Pipe	Liquid Pipe
PMBL5620		

■ Y branch

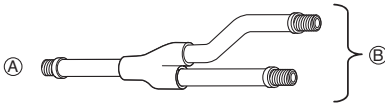

- Ⓐ To Outdoor Unit
- Ⓑ To BD Unit

• Ensure that the branch pipes are attached horizontally or vertically (see the diagram below.)

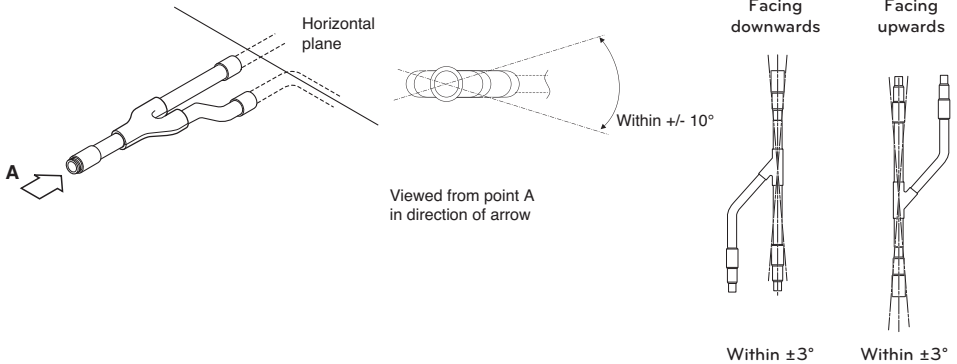

• Branch pipe should be insulated with the insulator in each kit.

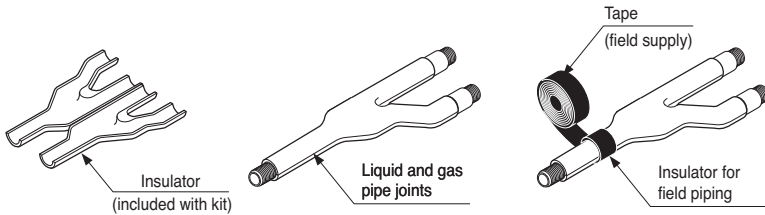

Installation

- This unit may be installed suspended from the ceiling or mounted on the wall.
- This unit may be installed horizontally, as shown in the diagram below. (Side B is facing up) However, it may be freely installed in any direction forward or back, and to the sides.
- Be sure to leave a 600 mm square opening for service and inspection as shown in the diagram below, for both ceiling - suspended installation and wall-mounted installation.
- This unit "does not require drain treatment" as it uses internal foam treatment as low-pressure piping insulation.
- Service direction is the side B and C
- The piping for the indoor unit may be led around in direction A
- The inclination of side B must be within ± 5 degrees forward or back or to the sides.

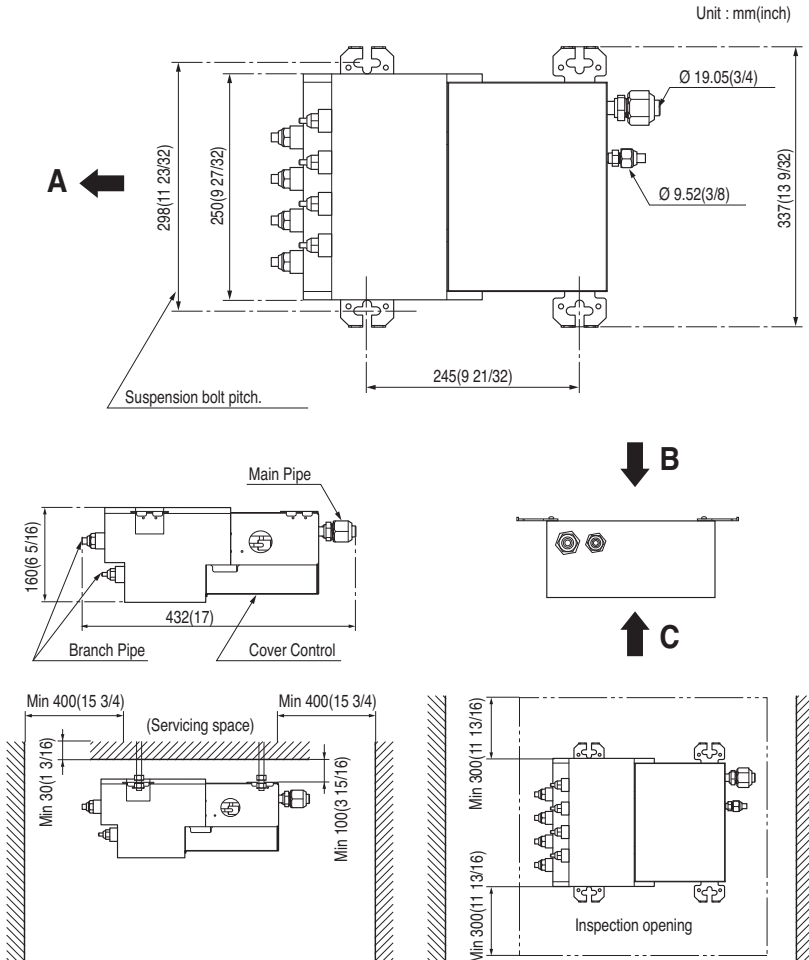

Installation of The Main Unit

NOTICE :

- This unit has two different installation types: (1) Ceiling-suspended type and (2) wall-mounted type.
- Choose the proper installation pattern according to the location of installation.
- The installation location for printed wiring board can be changed.
Follow the procedure specified in the "CONNECTING THE WIRING" section to change the location.

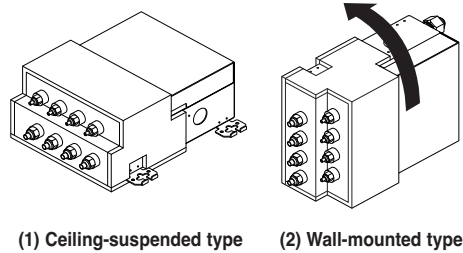

(1) Ceiling-suspended type

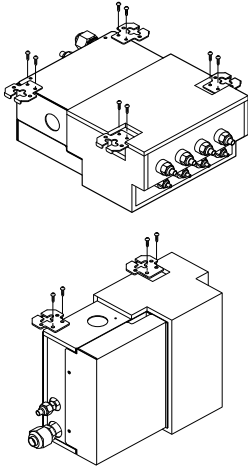

Procedure

- (1) Fix the furnished hanger metal with two screws. (4 locations in total).
- (2) Using an insert-hole-in-anchor, hang the hanging bolt.
- (3) Install a hexagon nut and a flat washer (locally-procured) to the hanging bolt as shown in the figure in the left, and lift the main unit to hang on the hanger metal.
- (4) After checking with a level that the unit is level, tighten the hexagon nut.
* The tilt of the unit should be within $\pm 5^\circ$ in front/back and left/right.

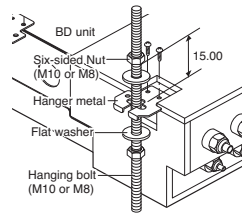

(2) Wall-mounted type

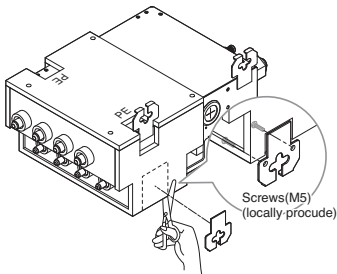

Procedure

- (1) Fix the furnished hanger metal with two screws. (3 locations in total).
 - (2) After checking with a level that the unit is level, fix the unit with the furnished wood screws.
* The tilt of the unit should be within $\pm 5^\circ$ in front/back and left/right.
- * Block up the parts of hanger holes (2 places) by using insulation PE after installing the hanger.

CAUTION

- Once a screw-hole on the main unit has had a screw hammered in, make sure to either hammer it again or cover it with aluminum tape. (This is to prevent condensation)
- Be sure to install the unit with the ceiling-side up.
- Do not install near bedrooms. the sound of refrigerant flowing through the piping may sometimes be audible.

Connecting the Cable between Indoor Unit, Distributor Unit and Outdoor Unit

Connect the cable to the Indoor unit

Connect the cable to the indoor unit by connecting the wires to the terminals on the control board individually according to the outdoor unit connection. (Ensure that the color of the wires of the outdoor unit and the terminal No. are the same as those of the indoor unit.)

The ground wire should be longer than the common wires.

The circuit diagram is not subject to change without notice.

When installing, refer to the electrical diagram behind the front panel of Indoor Unit.

The wiring for the outdoor unit can be found on the inside of the Outdoor Unit control cover.

Pipes and wires should be purchased separately for installation of the product.



RECOMMENDATION:

- The circuit diagram is subject to change without notice.
- Be sure to connect wires according to the wiring diagram.
- Connect the wires firmly, so that they can not be pulled out easily.
- Connect the wires according to color codes by referring to the wiring diagram.



RECOMMENDATION: Provide a circuit breaker between power source and the outdoor unit as shown below.

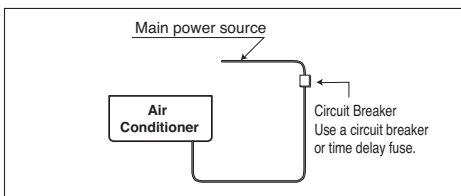

Outdoor Unit Capacity (kBtu/h class)	Power source	Fuse or breaker Capacity
18/24	1Ø, 208/230 V	20 A
30/36	1Ø, 208/230 V	25 A
48/54	1Ø, 208/230 V	40 A
60	1Ø, 208/230 V	45 A



RECOMMENDATION: The power cord connected to the outdoor unit should comply with the following specifications: NRTL Recognized (for example, UL or ETL recognized and CSA certified).

■ Power supply cable

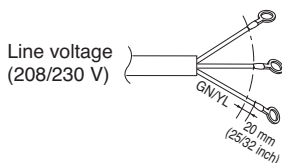

As always, final wire selection is governed by local codes and should be installed by a licensed professional contractor.

	The minimum recommended wire size
18/24 kBtu/h	AWG 14-3
30/36 kBtu/h	AWG 12-3
48/54 kBtu/h	AWG 10-3
60 kBtu/h	AWG 8-3

■ Connecting cable

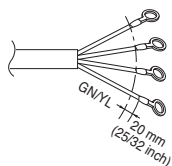

The power connecting cable between the outdoor and indoor units must comply with the following specifications: NRTL Recognized (for example, UL or ETL recognized and CSA certified).

AWG 18-4 is the minimum recommended wire size, however, the selected conductors must comply with local codes and be suitable for installation in wet locations.



RECOMMENDATION: When using separate wires as the power cord, please secure separate wires in the control box panel using tie wraps to hold all wires in place.

◆ Precautions when laying power and ground wiring

Use round pressure terminals for connections to the power terminal block. When laying ground wiring, you must use round pressure terminals.

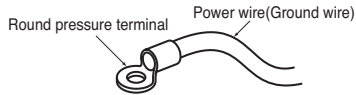

When none are available, follow the instructions below.

- Do not connect wiring of different thicknesses to the power terminal block. (Slack in the power wiring may cause abnormal heat.)
- When connecting wiring which is the same thickness, do as shown in the figure below.

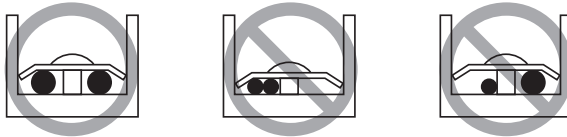

- For wiring, use the designated power wire and connect firmly, then secure to prevent outside pressure being exerted on the terminal block.
- Use an appropriate screwdriver for tightening the terminal screws. A screwdriver with a small head will strip the head and make proper tightening impossible.
- Over-tightening the terminal screws may break them.

Connect the cable to the Distributor unit

- Connect refrigerant pipes and connection wires to the appropriate ports made with matching alphabets (A, B and C) on this unit.
- Follow the instructions on the wiring nameplate to connect the connection wires of indoor/outdoor units to terminal board numbers.(1, 2 and 3) Always fix each ground wire separately with a ground screw.(See the figure below.)
- After completing the wiring, fix the outer coating of wires securely with wire clamps. The wire clamp on indoor unit side is furnished. Follow the procedure below to install.
- Refer to the circuit diagram on the control cover inside outdoor unit.

NOTICE :

The terminal board numbers are arranged from top to bottom in order of 1, 2 and 3.

In Case of 3 rooms

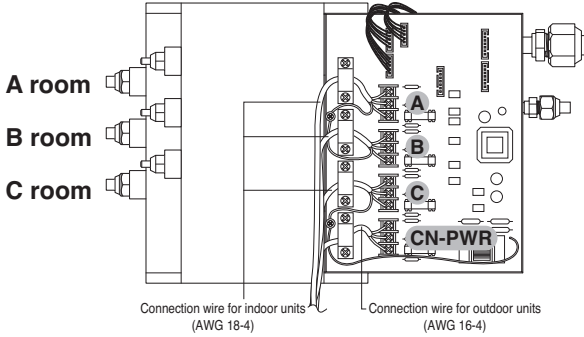

⚠ WARNING
 Do not use tapped wires, stand wires, extension cords, or starburst connections, as they may cause overheating, electrical shock, or fire.

- (1) Remove the control cover. Loosen the two screws, and slide the cover in the direction of the arrow.

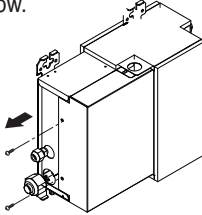

- (2) Pull out connection cable through conduit. After conduit to the panel, fix nut to the opposite side of panel. Pass the connection cable through the hole.

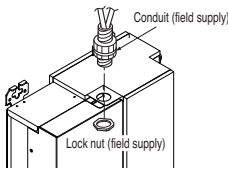

- (3) Perform wiring with reference the wiring diagram on a control cover of outdoor unit. Allow 300 mm (11 13/16 inch) for the pulling-out section of harness. Fix the wires completely with wire clamps (4 locations).

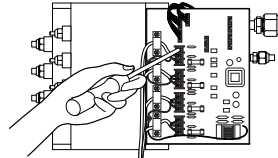

- (4) Put in the cover in the direction of the arrow then tighten the screws.

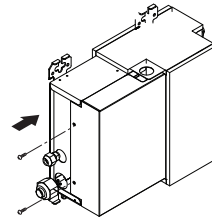

Connect the cable to the Outdoor unit

1. Remove the control cover from the unit by loosening the screw.
Connect the wires to the terminals on the control board individually as the following.
2. Secure the cable onto the control board with the holder (clammer).
3. Re-attach the cover control to the original position using the screws.

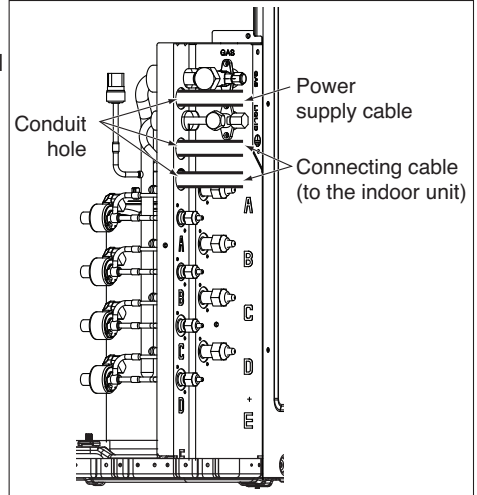

* The feature may be changed according to the type of model.

18/24 kBTu/h class

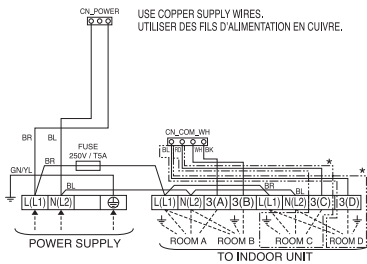

30/36 kBTu/h class

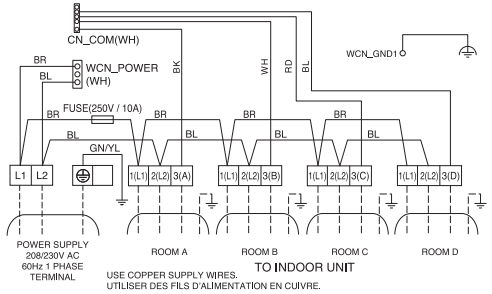

48/54 kBTu/h class

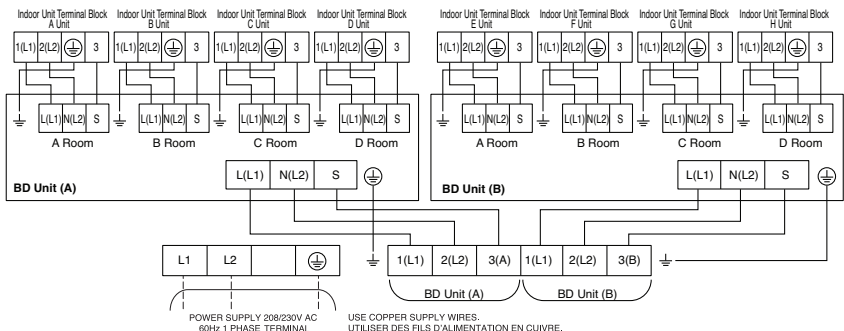

60 kBtu/h class

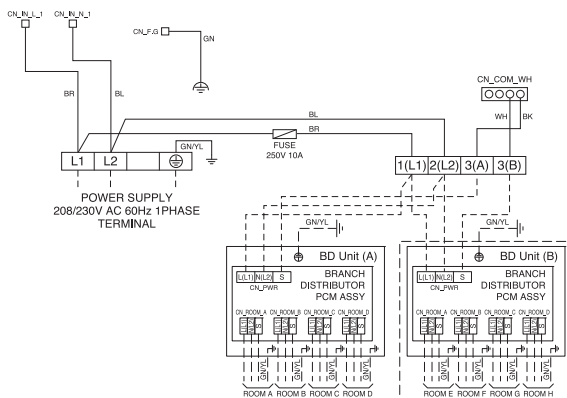
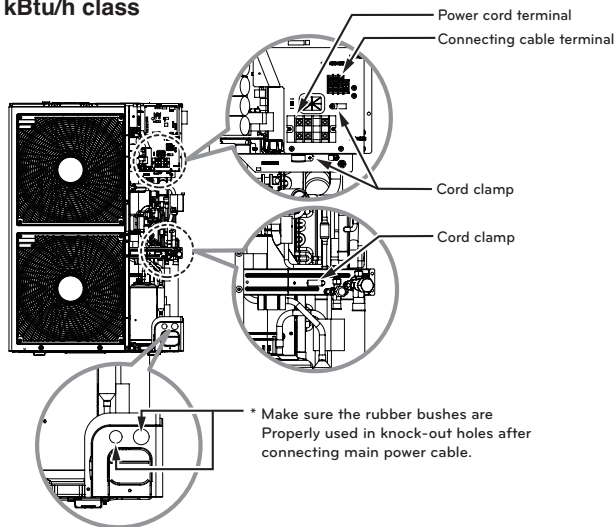

NOTICE :

1. Use connection cable NRTL(UL, ETL, CAS...) listed and stranded copper(4) THHN conductors, sunlight (UV) resistant ROHS compliant PVC jacket 600 V direct burial listed, approved for wet conditions. Temperature rated for $-20\text{ }^{\circ}\text{C}(-4\text{ }^{\circ}\text{F})$ to $90\text{ }^{\circ}\text{C}(194\text{ }^{\circ}\text{F})$. And this cable should be enclosed in conduit.

⚠ WARNING

- Be sure to comply with local and national codes while running the wire from the indoor unit to the outdoor unit(size of wire and wiring method, etc).
- Every wire must be connected firmly.
- No wire should be allowed to touch refrigerant tubing, the compressor or any moving parts.
- The communication wirings of air conditioner should be separate and isolated from external device's electric wiring such as computers, elevator, radio & Television broadcasting facilities, as well as medical imaging offices.

Connection method of the connecting cable(Example)

- (1) Remove the side panel and knockouts of conduit panel. (for low voltage line)
- (2) Pull out connection cable through conduit.
- (3) After conduit to the panel, fix nut to the opposite side of panel.
- (4) Pass the connection cable through the hole.
- (5) Properly connect the cable on the terminal block.
- (6) Fix the connection cable with cord clamp provided on the unit not to have strain at the terminal when the connection cable is pulled outside up to a 35 pound weight

! WARNING

Loose wiring may cause the terminal to overheat or result in unit malfunction. A fire hazard may also exist. Therefore, be sure all wiring is tightly connected.

When connecting each power wire to the corresponding terminal, follow instructions "How to connect wiring to the terminals" and fasten the wire tightly with the fixing screw of the terminal plate.

How to connect wiring to the terminals

⇒ For strand wiring

- (1) Cut the wire end with a wire cutter or wire-cutting pliers, then strip the insulation to expose the strand wiring about 10 mm (3/8").
- (2) Using a screwdriver, remove the terminal screw(s) on the terminal plate.
- (3) Using a round terminal fastener or pliers, securely clamp each stripped wire end with a round terminal.
- (4) Position the round terminal wire, and replace and tighten the terminal screw using a screwdriver.

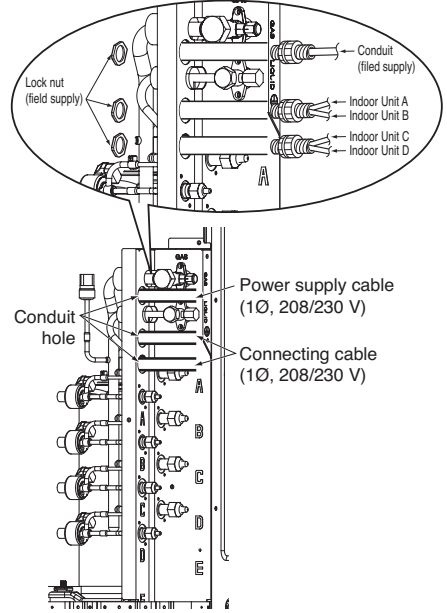

* The feature may be changed according to the type of model.

Power supply cable

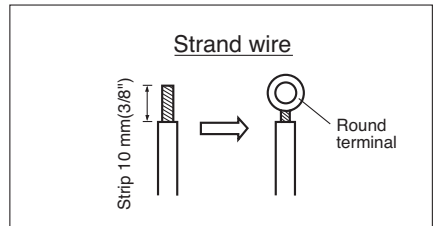

Connecting Cable

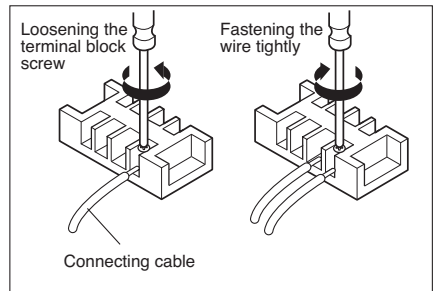

Checking the Drainage, Insulating the Pipe and Special Piping Applications

Checking the drainage

1. Remove the Air Filter.

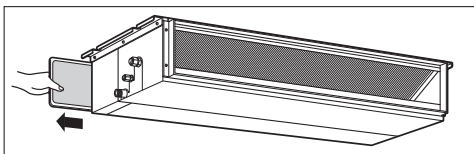

2. Check the drainage.

- Spray one or two glasses of water upon the evaporator.
- Ensure that water flows drain hose of indoor unit without any leakage.

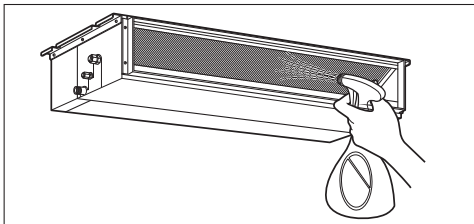

※ The figure can be changed according to model.

Insulating the Pipe and Special Piping Applications

Insulate the piping by wrapping the connecting portion of the indoor unit with insulation material and secure it with two kinds of vinyl tape.

- If you want to connect an additional drain hose, the end of the drain outlet should be routed above the ground. Secure the drain hose appropriately. If you want to install the wires to be connected the Conduit Hall.

In cases where the outdoor unit is installed below the indoor unit perform the following:

1. Tape the piping, drain hose and connecting cable from down to up.
2. Secure the taped piping along the exterior wall using saddle or equivalent.

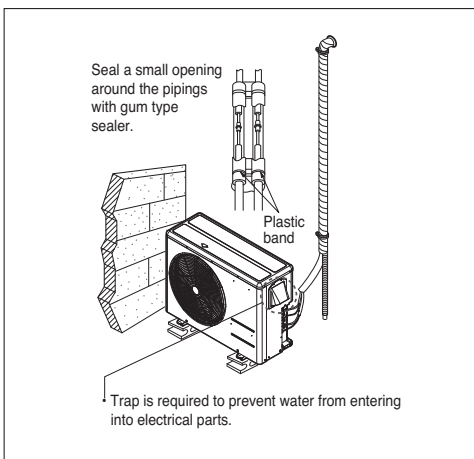

In cases where the Outdoor unit is installed above the Indoor unit perform the following.

1. Tape the piping and connecting cable from down to up.
2. Secure the taped piping along the exterior wall. Form a trap to prevent water entering the room.
3. Secure the piping onto the wall using a saddle or equivalent.

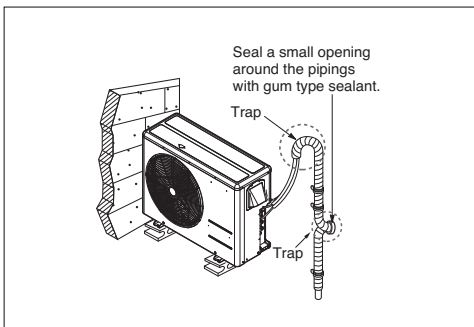

Air Purging and Evacuation

Air and moisture remaining in the refrigerant system have undesirable effects as indicated below.

1. Pressure in the system rises.
2. Operating current rises.
3. Cooling(or heating) efficiency drops.
4. Moisture in the refrigerant circuit may freeze and block capillary tubing.
5. Water may lead to corrosion of parts in the refrigeration system.

Therefore, the indoor/outdoor unit and connecting tube must be checked for leaks, and vacuumed to remove non-condensable gas and moisture in the system.

Leak Checking

Preparation

- Check that each tube(both liquid and gas side tubes) between the indoor and outdoor units have been properly connected and all wiring for the test run has been completed. Remove the service valve caps from both the gas and the liquid sides on the outdoor unit. Check that both the liquid and the gas side service valves on the outdoor unit are kept closed at this stage.

Leakage test

- Connect the manifold valve(with pressure gauges) and dry nitrogen gas cylinder to this service port with charge hoses.

⚠ CAUTION

Be sure to use a manifold valve for leak testing. The high side manifold valve must always be kept closed.

- Pressurize the system to no more than 550 P.S.I.G. with dry nitrogen gas and close the cylinder valve when the gauge reading reached 550 P.S.I.G. Next, test for leaks with liquid soap.

⚠ CAUTION

To avoid nitrogen entering the refrigerant system in a liquid state, the top of the cylinder must be higher than its bottom when you pressurize the system. Usually, the cylinder is used in a vertical standing position.

NOTICE : Leakage testing should be done for each indoor unit connection set, separately.

1. Do a leakage test of all joints of the tubing(both indoor and outdoor) and both gas and liquid side service valves with soap bubbles. Bubbles indicate a leak. Be sure to wipe off the soap with a clean cloth.
2. After the system is found to be free of leaks, relieve the nitrogen pressure by loosening the charge hose connector at the nitrogen cylinder. When the system pressure is reduced to normal, disconnect the hose from the cylinder.

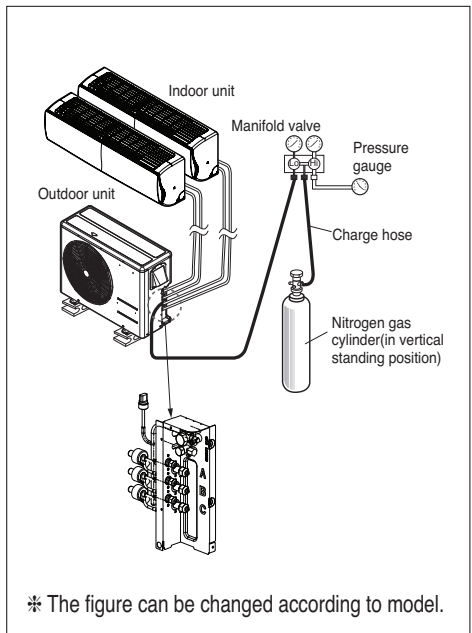

Evacuation

1. Connect the charge hose end described in the preceding steps to the vacuum pump to evacuate the tubing and indoor unit. Confirm the "Lo" knob of the manifold valve is open. Then, run the vacuum pump. The operation time for evacuation varies with tubing length and capacity of the pump. The following table shows the time required for evacuation.

Required time for evacuation when 30 gal/h vacuum pump is used	
If tubing length is less than 10m (33 ft)	If tubing length is longer than 10m (33 ft)
Less than 0.5 Torr	Less than 0.5 Torr

2. When the desired vacuum is reached, close the "Lo" knob of the manifold valve and stop the vacuum pump.

Finishing the job

1. With a service valve wrench, turn the valve stem of liquid side valve counter-clockwise to fully open the valve.
2. Turn the valve stem of gas side valve counter-clockwise to fully open the valve.
3. Loosen the charge hose connected to the gas side service port slightly to release the pressure, then remove the hose.
4. Replace the flare nut and its bonnet on the gas side service port and fasten the flare nut securely with an adjustable wrench. This process is very important to prevent leakage from the system.
5. Replace the valve caps at both gas and liquid side service valves and fasten them tight.

This completes air purging with a vacuum pump. The air conditioner is now ready for test running.

NOTICE

: Repeat evacuation procedure for each indoor unit.

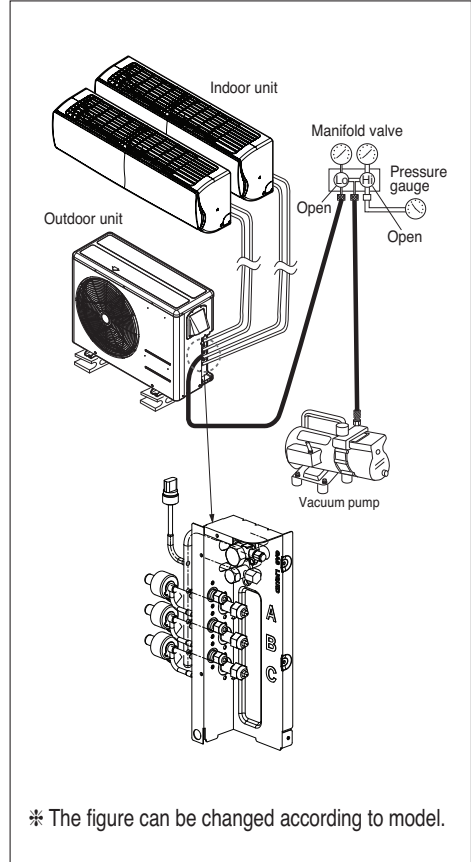

Charging

■ If installed total piping length is more than standard total length, additional refrigerant charging is necessary.

Below standard total piping length, additional refrigerant charging is not required.

Multiple Piping Models

Unit:m(ft)

Outdoor Unit Capacity (kBtu/h class)	Max total length of all pipes (A+B)/(A+B+C)/(A+B+C+D)	Max length of each pipe (A/B/C/D)	Min length of each pipe (A/B/C/D)	Additional Refrigerant Unit : g/m (oz/ft)	Standard Total Piping Length (No Add'l refrigerant)
18	50(164)	25(82)	3(9.8)	20(0.22)	30(98.4)
24	70(230)	25(82)	3(9.8)	20(0.22)	30(98.4)
30	75(246)	25(82)	3(9.8)	20(0.22)	30(98.4)
36	75(246)	25(82)	3(9.8)	20(0.22)	30(98.4)

Distributor Type Model

Unit:m(ft)

Outdoor Unit Capacity (kBtu/h class)	Main Piping Length		Branch Piping Length	
	Standard Length	Additional Refrigerant Unit : g/m (oz/ft)	Standard Length	Additional Refrigerant Unit : g/m (oz/ft)
48	5(16.4)	50(0.55)	5(16.4)	20(0.22)
54	5(16.4)	50(0.55)	5(16.4)	20(0.22)
60	5(16.4)	50(0.55)	5(16.4)	20(0.22)

Important:

If you are ever uncertain of the unit charge, reclaim, evacuate and weigh in the correct charge using the charge amount specified on the Unit's specification label.

Multiple Piping Models

Additional charge(oz) = (Total Installation Piping Length-Standard Total Piping Length) x 0.22

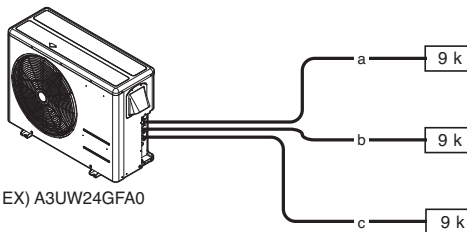

Each branch pipe
 a = 82 ft
 b = 16 ft
 c = 49 ft

※ Additional Charge
 = {(82+16+49)-98.4} x 0.22 = 10.69 oz

Distributor type Models

$$\begin{aligned} \text{Additional charge (oz)} = & ((\text{Total Main piping Length} - \text{Main Standard Length}) \times 0.55 \\ & + (\text{A Room Branch Length} - \text{Standard Length}) \times 0.22 \\ & + (\text{B Room Branch Length} - \text{Standard Length}) \times 0.22 \\ & + (\text{C Room Branch Length} - \text{Standard Length}) \times 0.22 + \dots) \\ & - \text{CF}(\text{Correction Factor}) \times 3.53 \end{aligned}$$

* CF = Max. number of connectable indoor unit – Total number of connected indoor unit

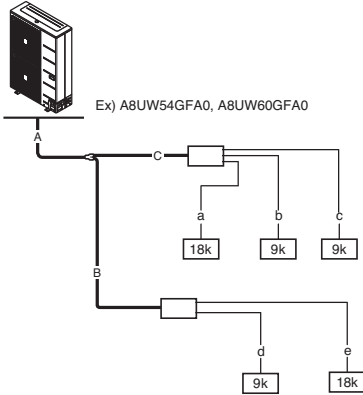

- Total main pipe(A+B+C)=98ft
- Each branch pipe
 - a = 33 ft
 - b = 26 ft
 - c = 16.4 ft
 - d = 10 ft
 - e = 33 ft

$$\begin{aligned} \diamond \text{ Additional Charge} & = ((98-16.4) \times 0.55 + (33-16.4) \times 0.22 \\ & + (26-16.4) \times 0.22 + (16.4-16.4) \times 0.22 \\ & + (10-16.4) \times 0.22 + (33-16.4) \times 0.22) \\ & - (8-5) \times 3.53 = 42.3 \text{ oz} \end{aligned}$$

* If the total additional charge value after calculation comes out to be negative, then do not consider additional charge.

Installation PI485

Fix the PI485 PCB as shown in Fig.

Detailed installation method refer to PI485 Installation Manual.

18 kBTu/h, 24 kBTu/h

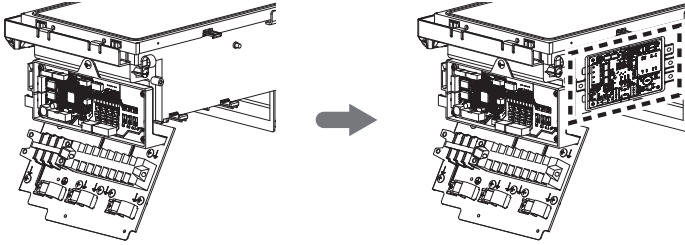

30 kBTu/h, 36 kBTu/h

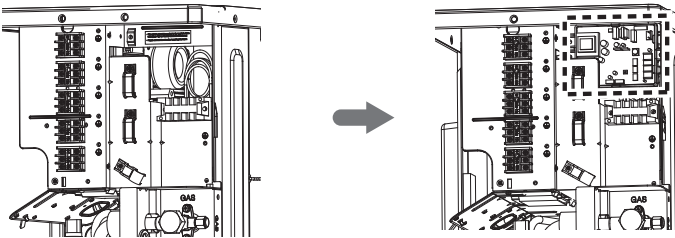

48 kBTu/h, 54 kBTu/h

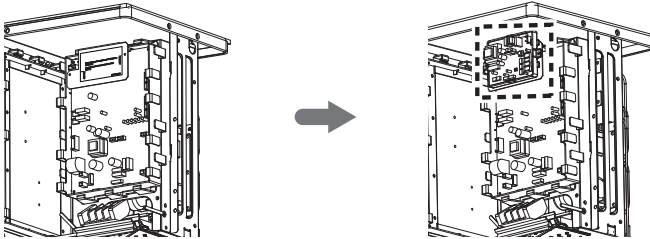

60 kBTu/h

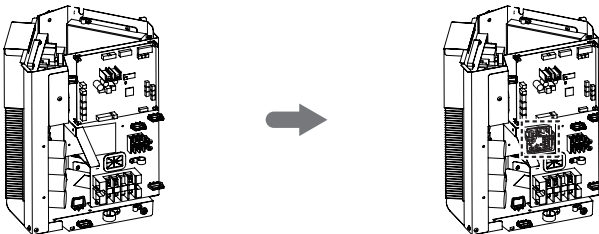

Test Running

- Check that all tubing and wiring have been properly connected.
- Check that the gas and liquid side service valves are fully open.

Prepare remote control

Remove the battery cover by pulling it according to the arrow direction. Insert new batteries making sure that the (+) and (-) of battery are installed correctly. Reattach the cover by pushing it back into position.

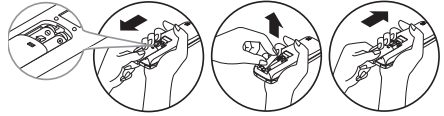

NOTICE :

- Use 2 AAA(1.5 volt) batteries. Do not use rechargeable batteries.
- Remove the batteries from the remote control if the system is not going to be used for a long time.

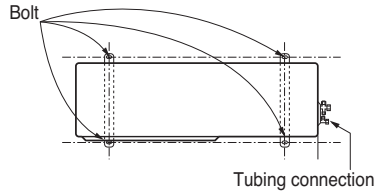

Evaluation of the performance

Operate unit for 15~20 minutes, then check the system refrigerant charge:

- Measure the pressure of the gas side service valve.
- Measure the temperature of the intake and discharge of air.
- Ensure the difference between the intake temperature and the discharge is more than 8 °C.
- For reference, the gas side pressure of optimum condition is as below.(Cooling)

Refrigerant	Outside ambient TEMP.	The pressure of the gas side service valve.
R410A	35 °C (95 °F)	8.5~9.5 kg/cm ² G (120~135 P.S.I.G.)

NOTICE :

If the actual pressure are higher than shown, the system is most likely over-charged, and charge should be removed. If the actual pressure are lower than shown, the system is most likely undercharged, and charge should be added. The air conditioner is now ready for use.

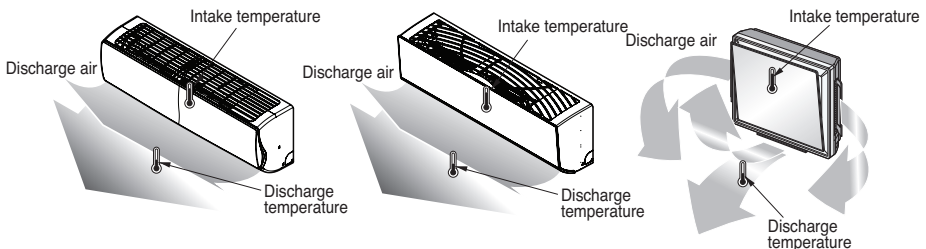

Function

DIP S/W Setting

If you set the DIP Switch when power is on, the change in setting is not applicable. The changing setting is enabled only when Power is reset.

18/24/30/36/48/54 k

60 k

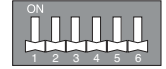
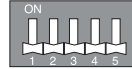

DIP Switch		Function		
1	2		3	4
		Normal Operation (No Function)		
		Forced Cooling Operation		
		Wiring Error Check		
		Saving Power Consumption (Step 1)		
		Saving Power Consumption (Step 2)		
		Mode Lock (Cooling)		
		Mode Lock (Heating)		
		Night Quiet Mode (Step 1)		
		Night Quiet Mode (Step 2)		
		Mode Lock (Cooling) + Night Quiet Mode (Step 1)		
		Mode Lock (Cooling) + Night Quiet Mode (Step 2)		
		Mode Lock (Cooling) + Saving Power Consumption (Step 1)		
		Mode Lock (Cooling) + Saving Power Consumption (Step 2)		
		Mode Lock (Heating) + Saving Power Consumption (Step 1)		
		Mode Lock (Heating) + Saving Power Consumption (Step 2)		

⚠ WARNING

When you set the DIP switch, you should turn off the circuit breaker or shut the power source of the product down.

⚠ CAUTION

- Unless the applicable DIP switch is set properly, the product may not work.
- If you want to set a specific function, request that the installer sets the DIP switch appropriately during installation.

18/24(1Ø) kBTu/h

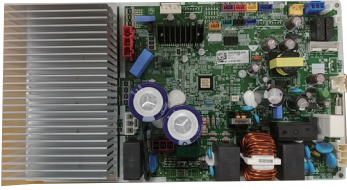

18(1Ø) kBTu/h 24(1Ø) kBTu/h

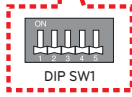
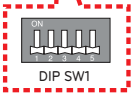

30/36(1Ø) kBTu/h

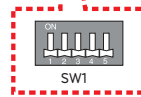
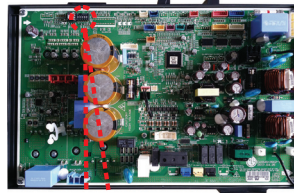

60(1Ø) kBTu/h

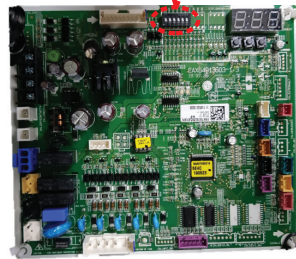
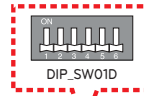

48/54(1Ø) kBTu/h

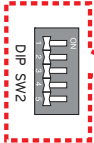
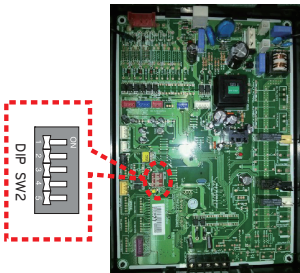

Forced Cooling Operation

Adding the refrigerant in winter.

Setting Procedure

1. Set the DIP Switch as follow after shutting the power source down.
2. Reset the power.
3. Check that the Red LED of PCB is on during work. (The indoor unit is operated by force.)
4. Add the specific amount of refrigerant.

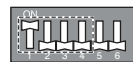

⚠ CAUTION

- When the green LED of PCB is on, compressor is going to be off because of low pressure.
- You should return the DIP Switch to operate normally after finishing the operation.

Wiring Error Check

You can check whether or not the wiring is correct.

Setting Procedure

1. Set the DIP Switch as follow after shutting the power source down.
2. Reset the power.
3. Check that the Re and Green LED of PCB are on during work. (The indoor unit is operated by force.)
4. If the wiring is correct, the Green LED will light up.

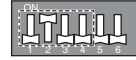

If the wiring is wrong, display as below
(Display only wrong connection.)

- Red LED : Piping Number
- Green LED : Wiring Number (Room)

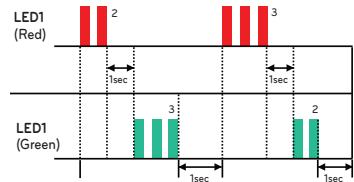

Example)

If the Red LED blinks twice and the Green LED blinks 3 times, 2nd pipe is connected to 3rd room.

5. You should return the DIP Switch to operate normally after finishing wiring error check.

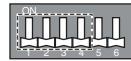
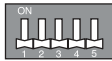
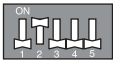

CAUTION

- If Indoor unit doesn't communicate to outdoor Unit, function could not be operated correctly.
- Only the wrong wiring connection is displayed. You should change connection correctly to operate the product.
- If Outdoor and Indoor temperature is too low in winter, the wiring error check function will not be operated. (Red LED is lighting)

Saving Power Consumption

Saving Power Consumption operation is the function which enables efficient operation by lowering the maximum power consumption value.

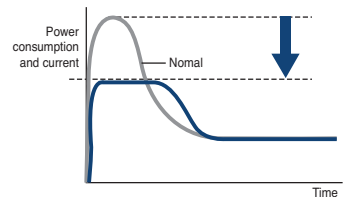

Setting Procedure

- 1 Set the DIP Switch as follow after shutting the power source down.
- 2 Reset the power.



Step 1



Step 2

Saving Power Consumption Current level.

Phase	1Ø		
Model	18/24 k	30/36 k	48/54/60 k
Step 1(A)	15	13	22
Step 2(A)	14	11	21

Saving Power Consumption with Mode Lock.

Saving Power
Consumption (step 1)
+ Mode Lock (Cooling)

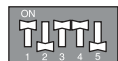

Saving Power
Consumption (step 1)
+ Mode Lock (Heating)



Saving Power
Consumption (step 2)
+ Mode Lock (Cooling)



Saving Power
Consumption (step 2)
+ Mode Lock (Heating)

**Night Quiet Mode**

Night Quiet Mode operation lowers the noise level of the outdoor unit by changing the comp frequency and fan speed. This function is operated all night long.

Setting Procedure

1. Set the DIP Switch as follow after shutting the power source down.

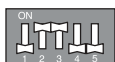
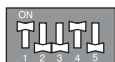

* Noise level :
Step 1 > Step 2

Step 1

Step 2

2. Reset the power.

Night Quiet Mode with Mode Lock.

Mode Lock (Cooling) +
Night Quiet Mode (step 1)



Mode Lock (Cooling) +
Night Quiet Mode (step 2)

**CAUTION**

- If comp frequency and fan speed are down, the cooling capacity may decrease accordingly.
- This function is only available for Cooling Mode.
- If you want to stop the Night Quiet Mode, Change the DIP Switch.
- If operating indoor unit is set by the fan speed "Power", Night Quiet Mode will be stopped until fan speed "Power" is changed.

Mode Lock

Setting Procedure

1. Set the DIP Switch as follow after shutting the power source down.

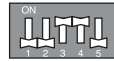
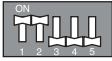

Only Cooling Mode

Only Heating Mode

2. Reset the power.

Mode Lock with Night Quiet Mode



Mode Lock (Cooling)
+ Night Quiet Mode
(step 1)

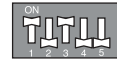

Mode Lock (Cooling)
+ Night Quiet Mode
(step 2)

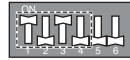
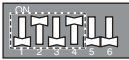

Saving Power Consumption with Mode Lock.

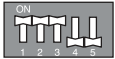

Mode Lock (Cooling)
+ Saving Power
Consumption (step 1)

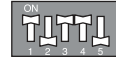

Mode Lock (Heating)
+ Saving Power
Consumption (step 1)

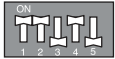
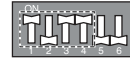
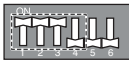

Mode Lock (Cooling)
+ Saving Power
Consumption (step 2)

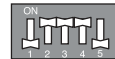

Mode Lock (Heating)
+ Saving Power
Consumption (step 2)

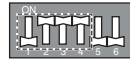
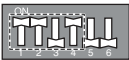

PCB Display(18/24/60 k Model Only)

It is useful to check the cycle data without LGMV.

Operating Method

Whenever you push the Tact Switch, the cycle information will be shown as below.

* After 1 page is displayed, subsequently 2 page is displayed.

Tact S/W 18/24/60 k	Item	Display		
		Example	1 page	2 page
1 time	Low Pressure	890 kpa	'LP'	'89'
2 time	Hi Pressure	2 900 kpa	'HP'	'290'
3 time	Discharge Temp.	85 °C	'DS'	'85'
4 time	Cond Out Temp.	-10 °C	'CS'	'-10'
5 time	Suction Temp.	-10 °C	'SS'	'-10'
6 time	ODU Air Temp.	-10 °C	'AS'	'-10'
7 time	Current	15 A	'A'	'15'
8 time	Voltage	230 V	'V'	'230'
9 time	Comp Hz	100 Hz	'F'	'100'
10 time	DC Link Voltage	230 V	'dc'	'230'

18 k



Only 60 k

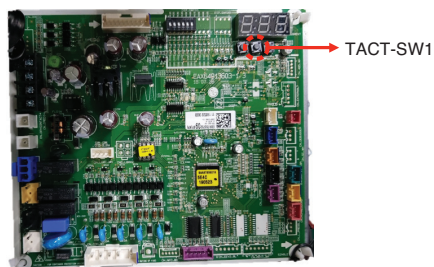

24 k



⚠ WARNING

When you push the Tact Switch, use the material non-conducting electricity.

Max Combination Capacity

Multi Piping Type

Capacity (kBtu/h)	Max Room No.	Combination Indoor Capacity (kBtu/h)	Max Combination Capacity (kBtu/h)
18	2	7,9,12,15	24
24	3	7,9,12,15,18,24	33
30	4	7,9,12,15,18,24	40
36	4	7,9,12,15,18,24	48

Distributor Type

Phase	Capacity (kBtu/h)	Max Room No.	Combination Indoor Capacity (kBtu/h)	Max Combination Capacity (kBtu/h)
1Ø	48	8	7,9,12,15,18,24,36	65
1Ø	54	8	7,9,12,15,18,24,36	73
1Ø	60	8	7,9,12,15,18,24,36	83

The combination of indoor unit is to be decided that the sum of indoor unit capacity index must be smaller than the maximum combination capacity of outdoor unit. We recommend to calculate indoor unit capacity like below.

If you do not follow our recommendation, it will have some problems in low ambient condition i.e. some indoor unit will not be able to heat very well in heating mode.

CALCULATION METHOD FOR THE CONNECTABLE TOTAL CAPACITY OF INDOOR UNIT

Sum up the capacity of all indoor unit, but high static duct and VAHU type indoor unit capacity multiplier 1.3 times in which multiplier is unless only HSD/VAHU are connected

Ex) 1. Outdoor unit : A8UW54GFA0(LMU540HV)(connectable maximum capacity is 73 kBtu)

Indoor unit:

AMNW24GBGA0[LMHN240HV], AMNW36GBGA0[LMHN360HV]

$(24+36) \times 1.2 = 60 \times 1.2 = 72$ kBtu : this combination is acceptable.

2. Out door unit: A8UW54GFA0(LMU540HV)

Indoor unit:

AMNW24GBGA0[LMHN240HV], AMNW24GBGA0[LMHN240HV], LMN078HVT

$[(24+24) \times 1.2] + 7 = [48 \times 1.2] + 7 = 69.4$ kBtu : this combination is acceptable.

3. Outdoor unit : A8UW54GFA0(LMU540HV)(connectable maximum capacity is 73 kBtu)

Indoor unit:

AMNW36GBGA0[LMHN360HV], AMNW36GBGA0[LMHN360HV]

$(36+36) \times 1.2 = 72 \times 1.2 = 86.4$ kBtu : this combination is not acceptable



US	1. Please call the installing contractor of your product, as warranty service will be provided by them. 2. If you have service issues that have not been addressed by the contractor, please call 1-888-865-3026.
CANADA	Service call Number # : (888) LG Canada, (888) 542-2623