

Job Name/Location:

Tag No:

Date:

For:	File	Resubmit
	Approval	Other

PO No.:

Architect: GC:

Engr: Mech:

Rep: (Company) (Project Manager)

LMU543HV

Multi F MAX Outdoor Unit

4.5 Ton Heat Pump

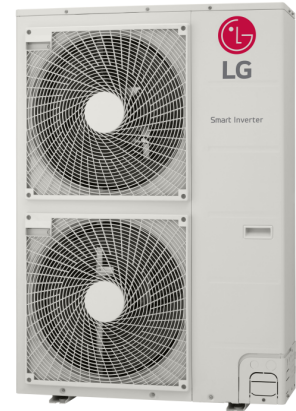

Performance:

Cooling Capacity (Min.-Rated-Max., Btu/h)	10,800-50,500-63,200
Heating Capacity (Min.-Rated-Max., Btu/h)	12,420-58,000-64,000
Max. Heating Capacity at 17°F (Btu/h)	49,530
Max. Heating Capacity at 5°F (Btu/h)	41,140
Max. Heating Capacity at -4°F (Btu/h)	35,790
Cooling COP @95°F (Rated)	3.69
Heating COP @47°F (Rated)	3.35

Cooling Nominal Test Conditions:
Indoor: 80°F DB / 67°F WB
Outdoor: 95°F DB / 75°F WB

Heating Nominal Test Conditions:
Indoor: 70°F DB / 60°F WB
Outdoor: 47°F DB / 43°F WB

Electrical:

Power Supply (V/Hz/Ø) ¹	208-230V, 60, 1
MOP (A)	40
MCA (A)	32.7
Cooling Rated Amps (A)	30.0
Heating Rated Amps (A)	30.0
Compressor (A)	22.0
Fan Motor (A)	1.6 x 2
Locked Rotor Amps (A)	22

MOP - Maximum Overcurrent Protection

MCA - Minimum Circuit Ampacity

Piping:

Refrigerant Charge (lbs.)	9.26
Liquid Line Connection (in., O.D.)	Ø3/8 x 1
Vapor Line Connection (in., O.D.)	Ø3/4 x 1
Maximum Total Piping ² (ft.)	475.7
Min. / Max. ODU to IDU Piping ³ (ft.)	32.8 / 229.6
Piping Length ⁴ (no add'l refrigerant, ft.)	180.4
Maximum Elevation between ODU and IDU (ft.)	98.4
Maximum Elevation between IDU and IDU (ft.)	49.2

ODU = Outdoor Unit

IDU = Indoor Unit

Features:

- R1 Scroll (Variable Speed) Compressor
- Auto operation
- Auto restart
- Self diagnosis
- Defrost / Deicing
- Low ambient cooling down to 14°F
- Soft start
- Restart delay (three [3] minutes)

Optional Accessories:

- PI-485 - PMNFP14A1
- AC Smart 5 - PACS5A000
- ACP 5 - PACP5A000
- MultiSITE™ Comm. Mgr. - PBACNBTR0A
- Power Distribution Indicator (PDI) Premium - PQNUD1S41
- Mobile LGMV - PLGMVW100
- Low Ambient Wind Baffle (Cooling Operation Down to -4°F) - ZLABGP04A x2
- Drain Pan Heater - PQSH1200

Required⁵ Accessories:

- 2 Port BD Unit - PMBD3620
- 3 Port BD Unit - PMBD3630
- 4 Port BD Unit - PMBD3640
- 4 Port BD Unit - PMBD3641

Proper sizing and installation of equipment is critical to achieve optimal performance. Split system air conditioners and heat pumps (excluding ductless systems) must be matched with appropriate coil components to meet ENERGY STAR® criteria. Ask your contractor for details or visit www.energystar.gov. (ENERGY STAR and the ENERGY STAR mark are registered trademarks owned by the U.S. Environmental Protection Agency.)

Operating Range:

Cooling (°F DB) ¹⁵	14 to 118
Heating (°F WB)	-4 to +64

Unit Data:

Refrigerant Type	R410A
Refrigerant Control	EEV
Sound Pressure (Cool / Heat) ±1 dB(A) ⁶	53 / 55
Net / Shipping Weight (lbs.)	194 / 218
Heat Exchanger Coating	Gold Fin™
Minimum No. of Indoor Units	2
Maximum No. of Indoor Units	8

Compressor:

Type	R1 Scroll
Quantity	1
Oil / Type	FVC68D

Fan:

Type	Propeller
Quantity	2
Motor / Drive	Brushless Digitally Controlled/Direct
Max. Airflow Rate (CFM)	1,942 x 2

Notes:

1. Acceptable operating voltage: 187V - 253V.
2. Piping lengths are equivalent.
3. 180.4 ft. of Main Piping + 49.2 ft. of Branch Piping.
4. 49.2 ft. of Main Piping + 131.2 of Branch Piping.
5. At least one branch distribution (BD) unit is required for system operation; a maximum of two can be installed per ODU with the use of a Y-branch accessory (PMBL5620).
6. Sound pressure levels are tested in an anechoic chamber under ISO Standard 3745.
7. All power / communication cable to be minimum 14 AWG from the ODU to the BD unit, and 14 AWG from the BD unit to the IDU.
8. All power / communication cable to be 4-conductor, stranded, shielded or unshielded, and must comply with applicable local and national codes. If shielded, the wire must be grounded to the chassis at the ODU only.
9. Power wiring size must comply with the applicable local and national codes.
10. See the Engineering Manual Capacity Tables for ODU sensible and latent capacities.
11. See the Engineering Manual Combination Tables for allocation of ODU rated capacity to each connected IDU when all are calling for full capacity. Allocation percentages should be applied to ODU capacity at design conditions.
12. Capacity is rated 0 ft. above sea level, with a 0 ft. level difference between ODU and IDUs, and the following refrigerant pipe lengths:
LMU483 / 543 / 601HV: 16.4 ft. Main + (16.4 ft. Branch x 8) = 147.6 ft. All capacities are net with a combination ratio between 95 - 105%.
13. Must follow installation instructions in the applicable LG installation manual.
14. See the Engineering Manual Capacity Tables for ODU capacity at design conditions.
15. Installation of an optional Low Ambient Wind Baffle Kit will allow operation down to -4°F in cooling mode.



For a complete list of available accessories, contact your LG representative.

For continual product development, LG reserves the right to change specifications without notice.

© LG Electronics U.S.A., Inc., Englewood Cliffs, NJ. All rights reserved. "LG Life's Good" is a registered trademark of LG Corp. /www.lghvac.com

SB_MultiF_MAX_LMU543HV_2023_05_31_064205

Job Name/Location: _____

LMU543HV
Multi F MAX Outdoor Unit
4.5 Ton Heat Pump



Tag No.: _____

Date: _____

PO No.: _____

[Unit: inch]

Chassis code : U60A

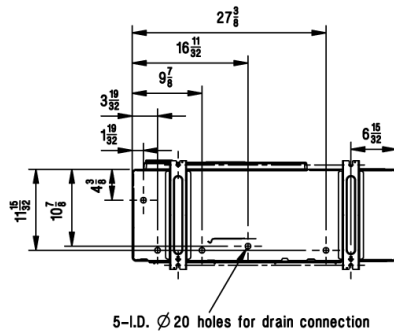
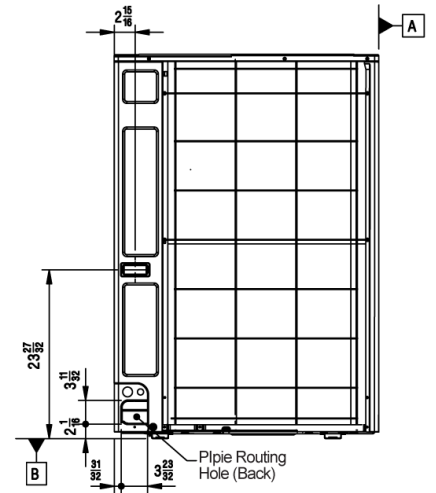
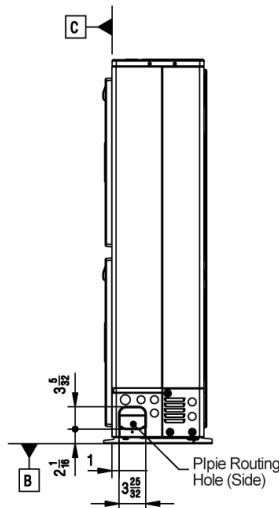
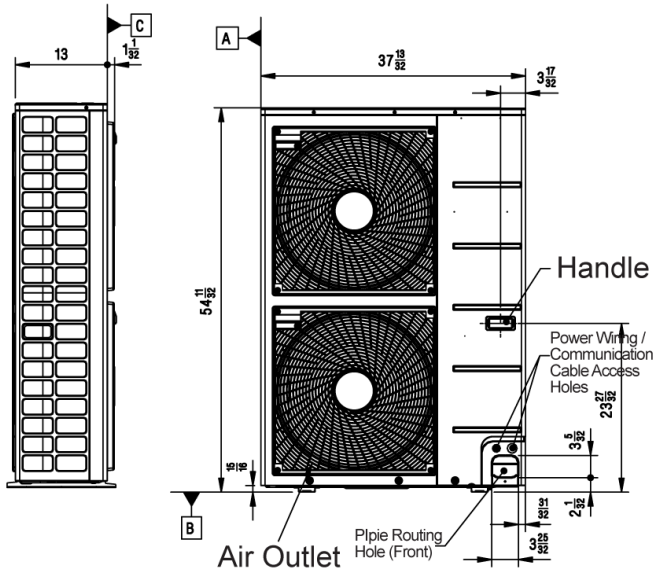
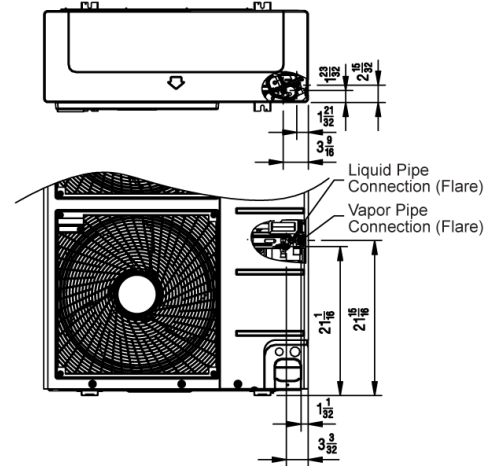
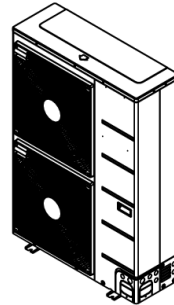
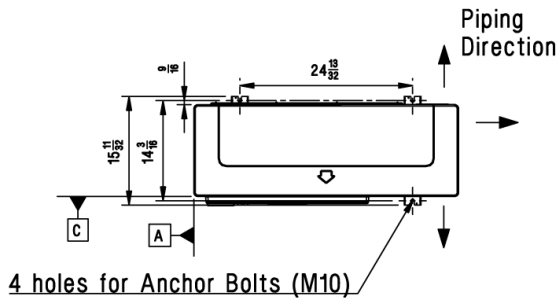

Symbols

- Piping Direction
- ▬ A Datum line

Notes:

1. Unit must be installed in compliance with the installation manual.
2. Unit must be grounded in accordance with the local or state regulations and applicable national codes.
3. All field-supplied electrical components and materials must comply with local, state, and national codes.
4. Electrical characteristics must be considered for electrical work and design. The capacity of power cable and circuit breaker for the outdoor unit must follow local, state, national, and manufacturer requirements.

Job Name/Location: _____

LMU543HV
Multi F MAX Outdoor Unit
4.5 Ton Heat Pump



Tag No.: _____

Date: _____

PO No.: _____

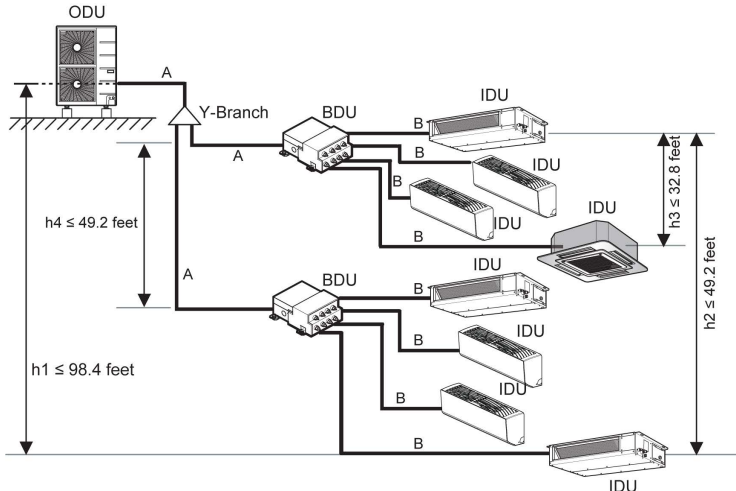

Example: outdoor unit with eight (8) indoor units and two (2) branch distribution units connected.
 ODU: Outdoor Unit.
 IDU: Indoor Unit.
 BDU: Branch Distribution Unit(s).
 A: Main Pipe.
 B: Branch Pipe (Branch Distribution Unit[s] to Indoor Unit[s]).

Multi F MAX Outdoor Unit Refrigerant Piping System Limitations.

Pipe Length (ELF = Equivalent Length of pipe in Feet)	Total piping length ($\Sigma A + \Sigma B$)	≤475.7 feet	
	Main pipe (Outdoor Unit to Branch Distribution Units: A)	Minimum (ΣA)	16.4 feet
		Maximum (ΣA)	≤180.4 feet
	Total branch piping length (ΣB)	≤295.3 feet	
Elevation Differential (All Elevation Limitations are Measured in Actual Feet)	Branch pipe (Branch Distribution Units to Indoor Units: B)	Minimum	16.4 feet
		Maximum	≤49.2 feet
	If outdoor unit is above or below indoor unit (h1)		≤98.4 feet
	Between the farthest two indoor units (h2)		≤49.2 feet
Between branch distribution unit and farthest connected indoor unit(s) (h3)		≤32.8 feet	
Between branch distribution units (h4)		≤49.2 feet	

Installing the Unit

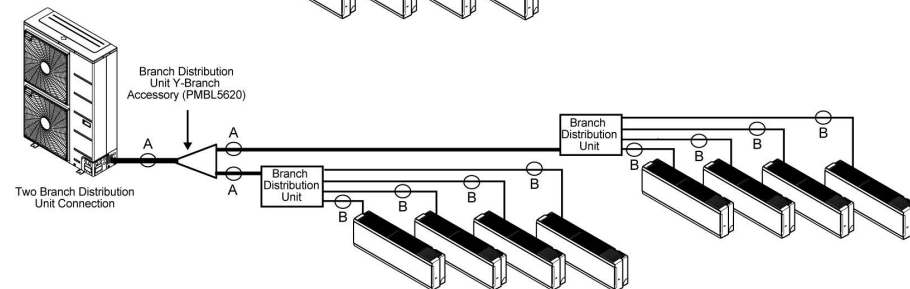

Multi F MAX Piping Sizes.

Piping	Main Pipe A (inch)	Branch Pipe B
Liquid	Ø3/8	Depends on the size of the indoor unit piping.
Vapor	Ø3/4	